

NXT UMOUNT™ **INSTALLATION MANUAL**

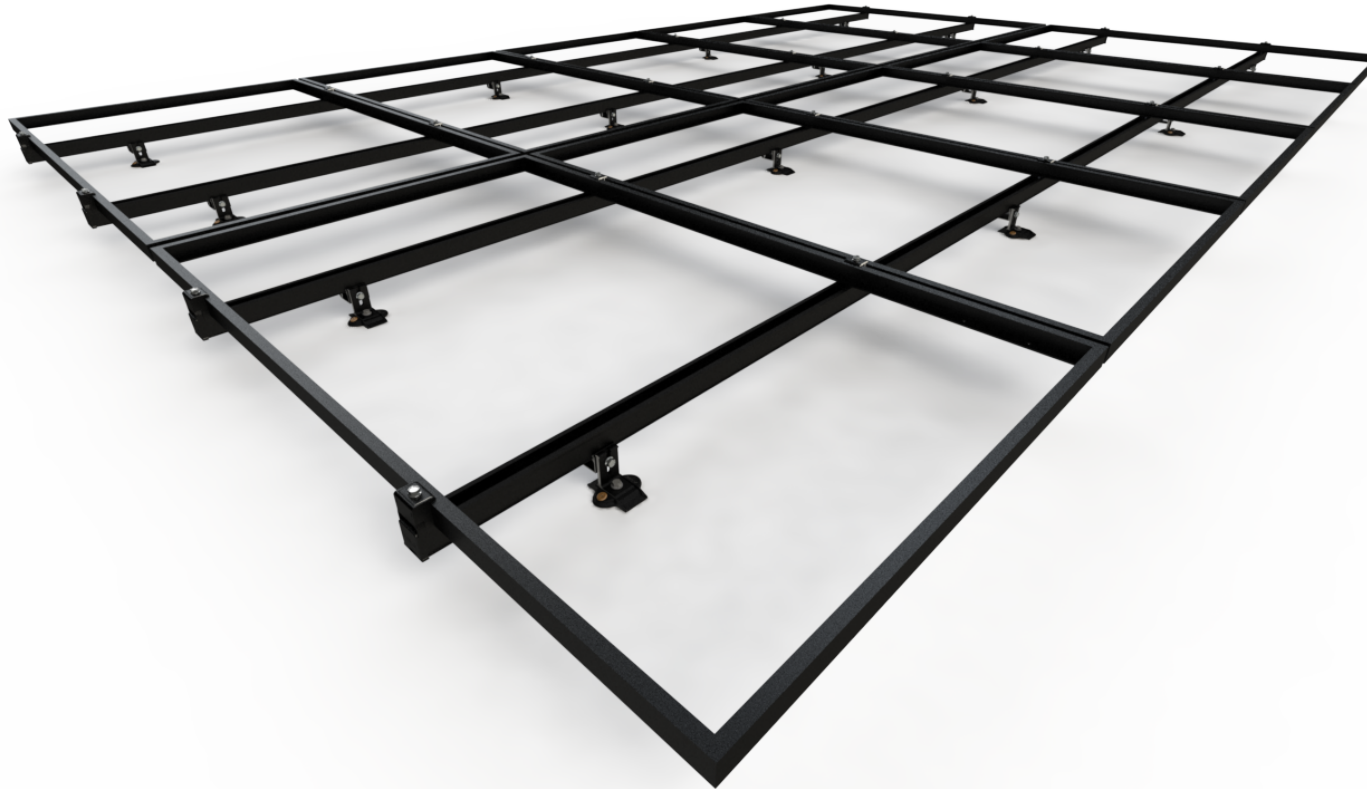

UNIRAC Code-Compliant Installation Manual

© 2023 by Unirac, Inc. All rights reserved.



NXT  **UMOUNT™**

INSTALLATION MANUAL

TABLE OF CONTENTS

NXT SYSTEM COMPONENTS.....	1-5
SYSTEM LAYOUT.....	6
THERMAL BREAK.....	7
STRONGHOLD ATTACHMENT WITH BUTYL INSTALLATION.....	8-11
ROOF PREP FOR LAG BOLT INSTALLATION.....	12
STRONGHOLD ATTACHMENT INSTALLATION.....	13
FLASHKIT PRO INSTALLATION.....	14
ATTACHMENT ORIENTATIONS.....	15-16
RAIL INSTALLATION.....	17
STRUCTURAL SPLICE INSTALLATION.....	18-20
MLPE MOUNTING.....	21
WIRE MANAGEMENT.....	22
COMBO CLAMP INSTALLATION.....	23
HIDDEN END CLAMP INSTALLATION.....	24
FINISHING TOUCHES.....	25
S-5! COMPONENTS.....	26-28
METAL ROOF RAIL CLAMP INSTALLATION.....	29
SYSTEM GROUNDING.....	30
BONDING CONNECTIONS & GROUNDING PATHS.....	31-34
CODE COMPLIANCE NOTES.....	35
COMPATIBLE MODULES.....	38-42

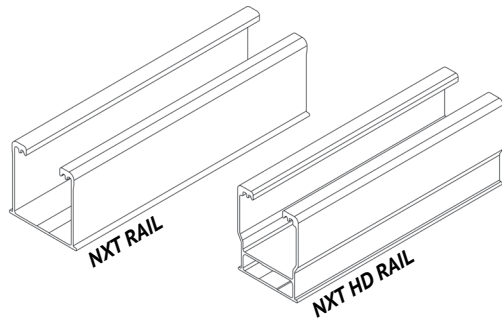

RAIL: Supports PV modules with built-in wire management. Aluminum extrusion, available in mill, or dark anodized.

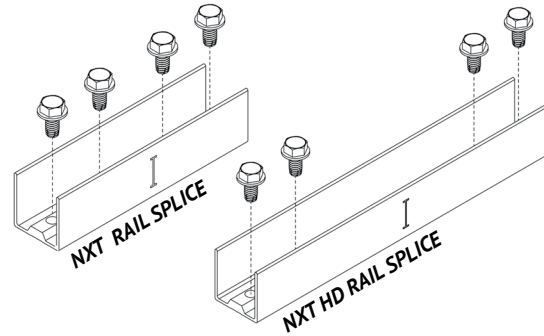

RAIL SPLICE: Internal Structural Splice joins, aligns, and electrically bonds rail sections into single length of rail. It is 6 inches long aluminum splice, pre-assembled with stainless-steel hardware.

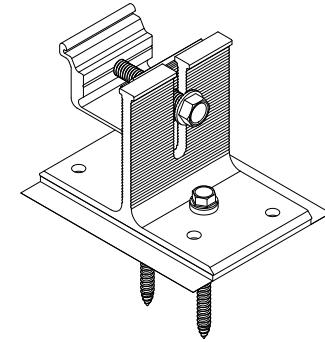

STRONGHOLD BUTYL ATTACHMENT KIT: Use to secure rails through roofing material to building structure. Kit includes the following:

- (1) Stronghold Rail Clamp For Butyl Attachment
- (1) Stronghold Attachment With Butyl Base
- (2) 3" Screw, HWH, SS, #14-14, TYPE AB, W/#14 EPDM washer

NOTE:

- Extra butyl pad available as separate SKU
- Additional deck screws are available as separate SKU

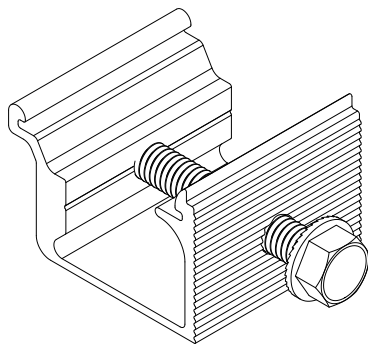

STRONGHOLD RAIL CLAMP: Use to secure rails to roof attachment. It is also available without the attachment kit for use with other mounting methods (Solarhooks, tilt legs, etc.)

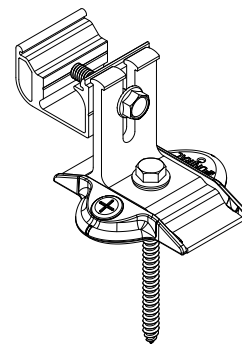

STRONGHOLD ATTACHMENT KIT: Use to secure rails through roofing material to building structure. Kit includes the following:

- (1) Stronghold Rail Clamp
- (1) Stronghold Attachment Base
- (2) 4" Stainless-Steel Lag Bolt with sealing EPDM washer.
- UNIRAC provided sealant (if applicable)

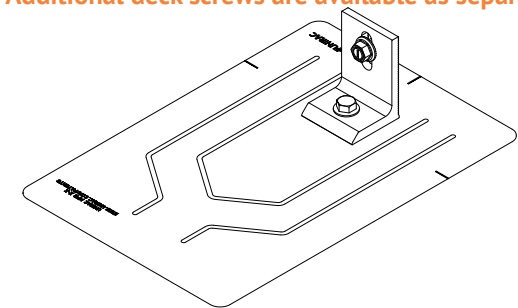

FLASHKIT PRO: Use with Stronghold Rail Clamp to secure rail through roofing material to building structure. Kit includes the following

- (1) Aluminum L-foot with EPDM Grommet
- (1) Aluminum Flashing
- (1) Stainless Steel Lag Bolt

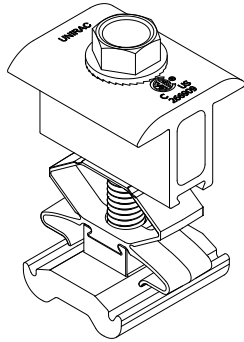

COMBO CLAMP

- Use as a mid clamp or an end clamp to secure and electrically bond modules to rails.
- Aluminum clamp with stainless-steel bonding pins, stainless-steel hex bolt, and plastic spring clip.
- Available in clear or dark finish.

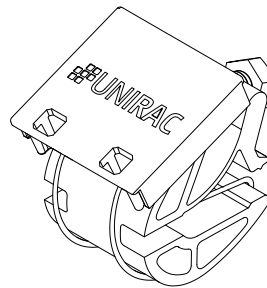

HIDDEN END CLAMP KIT

- Used as an end clamp to secure the modules to rails.
- The aluminum clamp is assembled with a stainless steel hex bolt, and a plastic end cap using a twist tie.

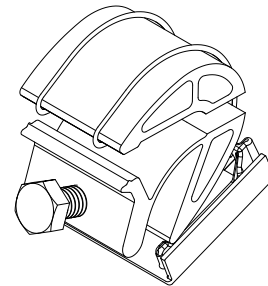

MLPE AND GROUNDING LUG

- Use to secure MLPE devices and ground wires to rails.
- Pre-assembled T-nut with stainless-steel bolt, stainless-steel grounding plate, and plastic retention clip.

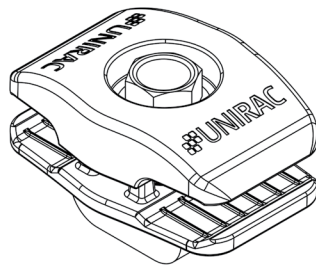

NS WIRE MANAGEMENT CLIP

Pre-assembled clamp to secure wires between rails.

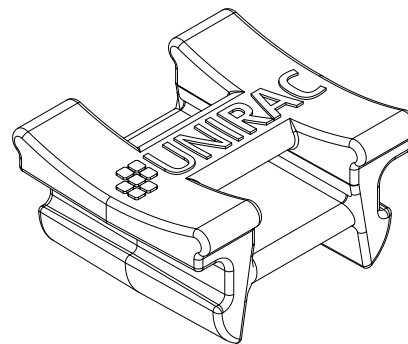

WIRE MANAGEMENT CLIP

Tool-less snap-in rail clip used to retain wires in rail or to secure wires between rails when used with a wire tie.

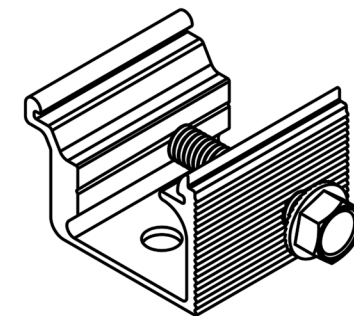

METAL ROOF RAIL CLAMP

- Use to secure rails to metal roof attachments.
- Pre-assembled aluminum clamp with stainless-steel bolt.

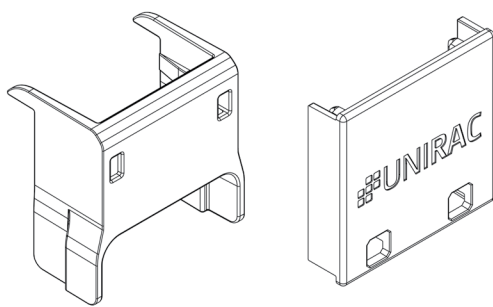

NXT UMOUNT RAIL END CAPS

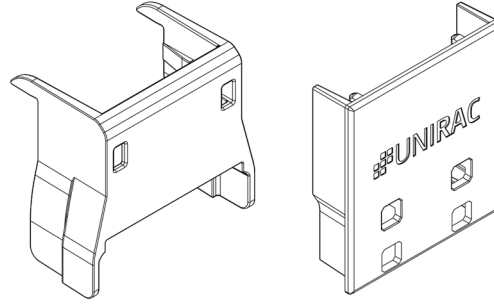

NXT UMOUNT HD RAIL END CAPS

- NXT UMOUNT Rail End Caps are engineered to provide a secure, seamless fit onto NXT UMOUNT rails.
- Designed for easy installation, they effectively close off the open ends of rails, enhancing the system’s finished appearance.
- In addition to improving aesthetics, the end caps help prevent pests and debris from entering the hollow rail cavities, contributing to the long-term durability and performance of the system.

WRENCHES AND TORQUE		
COMPONENT	WRENCH OR SOCKET SIZE	RECOMMENDED TORQUE (FT-LBS)
Rail Splice	1/2"	15
HD Rail Splice	1/2"	15
Stronghold Rail Clamp	1/2"	20
Combo Mid-End Clamp	1/2"	15
Hidden End Clamp	1/2"	15
MLPE & Grounding Lug	1/2"	10
NS Wire Management Clip	1/2"	3-7
Metal Roof Rail Clamp	1/2"	15
Stronghold Attachment #14 Screw	3/8"	#N/A



Any components showing signs of damage that compromise safety shall be replaced immediately.

PART	DESCRIPTION	PART NUMBER	MADE IN USA PART NUMBER
RAIL	NXT UMOUNT RAIL - 168" MILL	168RLM1	168RLM1-US
	NXT UMOUNT RAIL - 168" DARK	168RLD1	168RLD1-US
	NXT UMOUNT RAIL - 185" MILL	185RLM1	185RLM1-US
	NXT UMOUNT RAIL - 185" DARK	185RLD1	185RLD1-US
	NXT UMOUNT RAIL - 96" MILL	096RLM1	096RLM1-US
	NXT UMOUNT RAIL - 96" DARK	096RLD1	096RLD1-US
	NXT UMOUNT RAIL - 84" MILL	084RLM1	084RLM1-US
	NXT UMOUNT RAIL - 84" DARK	084RLD1	084RLD1-US
	NXT UMOUNT HD RAIL - 185" MILL	185NUHDM	185NUHDM-US
	NXT UMOUNT HD RAIL - 185" DARK	185NUHDD	185NUHDD-US
	NXT UMOUNT HD RAIL - 246" MILL	246NUHDM	246NUHDM-US
	NXT UMOUNT HD RAIL DARK - 246" DARK	246NUHDD	246NUHDD-US
RAIL SPLICE	NXT UMOUNT RAIL SPLICE	RLSPLCM2	RLSPLCM2-US
	NXT UMOUNT HD RAIL SPLICE	NUHDSPLC	NUHDSPLC-US
STRONGHOLD ATTACHMENT KIT	STRONGHOLD ATT KIT COMP MILL	SHCPKTM1	N/A
	STRONGHOLD ATT KIT COMP DRK	SHCPKTD1	N/A
STRONGHOLD RAIL CLAMP	STRONGHOLD RAIL CLAMP MILL	SHCLMPM2	SHCLMPM2-US
	STRONGHOLD RAIL CLAMP DRK	SHCLMPD2	SHCLMPD2-US
STRONGHOLD BUTYL ATTACHMENT KIT	STRONGHOLD BUTYL ATT KIT #14S MILL	SHBUTYLM2	SHBUTYLM2-US
	STRONGHOLD BUTYL ATT KIT #14S DARK	SHBUTYLD2	SHBUTYLD2-US
FLASHKIT PRO	FLASHKIT PRO, DRK 10PK	004055D	N/A
	FLASHKIT PRO, MILL 10PK	004055M	N/A
COMBO CLAMP	NXT UMOUNT COMBO CLAMP - MILL	CCLAMPM1	N/A
	NXT UMOUNT COMBO CLAMP - DARK	CCLAMPD1	CCLAMPD1-US
HIDDEN END CLAMP KIT	NXT HIDDEN END CLAMP W/ CAP	NUHECLMP1	N/A
MLPE AND GROUNDING LUG	NXT UMOUNT MLPE & GROUNDING LUG	NULGMLP1	NULGMLP1-US
NS WIRE MANAGEMENT CLIP	NXT UMOUNT NS WIRE MGMT CLIP	WRMCNSD1	N/A
WIRE MANAGEMENT CLIP	NXT UMOUNT WIRE MGMT CLIP	WRMCLPD1	N/A

Components List (Continued on Next Page)

PART	DESCRIPTION	PART NUMBER	MADE IN USA PART NUMBER
N-S BONDING CLAMP	MODULE-TO-MODULE N-S BONDING CLAMP	008000U	N/A
WIRE BONDING CLIP W/ 8AWG	WIRE BONDING CLIP W/ 8AWG	008015S	N/A
EXTRA BUTYL PATCHES	EXTRA BUTYL PAD - SH, KIT	XTRABUTL-SH	XTRABUTL-SH-US
DIRECT-TO-DECK SCREWS	#14-14 x 3.0 TYPE AB	003251W	N/A
METAL ROOF RAIL CLAMP	RAIL CLAMP ASSEMBLY MILL, METAL ROOF	NUMTLCLMPM	NUMTLCLMPM-US
	RAIL CLAMP ASSEMBLY DARK, METAL ROOF	NUMTLCLMPD	NUMTLCLMPD-US
MLPE MOUNT	UNIVERSAL MLPE MOUNT	N/A	MLPEMNT-US
END CAPS	NXT UMOUNT RAIL AND COMBO CLAMP CAP KIT	ENDCAPD1	N/A
	NXT UMOUNT HD RAIL AND COMBO CLAMP CAP KIT	NUHDCAPKIT	N/A

PLANNING YOUR NXT UMOUNT INSTALLATIONS

The installation can be laid out with rails parallel to the rafters or perpendicular to the rafters. Note that NXT UMOUNT rails make excellent straight edges for doing layouts.

Center the installation area over the structural members as much as possible. Leave enough room to safely move around the array during installation. Some building codes and fire codes require minimum clearances around such installations, and the installer should check local building code requirements for compliance.

The length of the installation area is equal to:

- the total width of the modules,
- plus 1/2" for each space between modules (for mid-clamp),
- plus 2" minimum (1" minimum for each MODULE END) (This will not be included when we use the hidden end clamp.)

LAYING OUT ROOF ATTACHMENTS

Locate and mark the position of the roof attachment within the installation area. Refer to Unirac NXT UMOUNT D&E Guide & U-Builder for rail spans and cantilevers. Follow module manufacturer installation requirements allowable spacing based on appropriate mounting locations. Modules should be placed such that they overhang the rails symmetrically.

NXT Rail Splices are fully structural and do not interfere with roof attachments or Combo Clamps. There is no need to determine splice locations at this stage.



Rail lengths and locations of L-feet for expansion joints will need to be determined at this stage in planning the array layout. For expansion joint requirements, See Page 7.

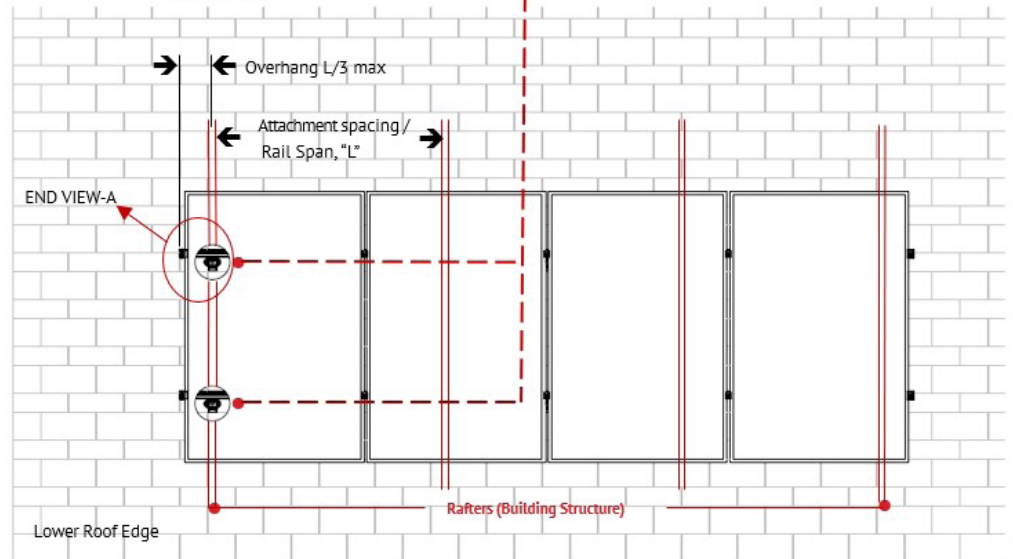
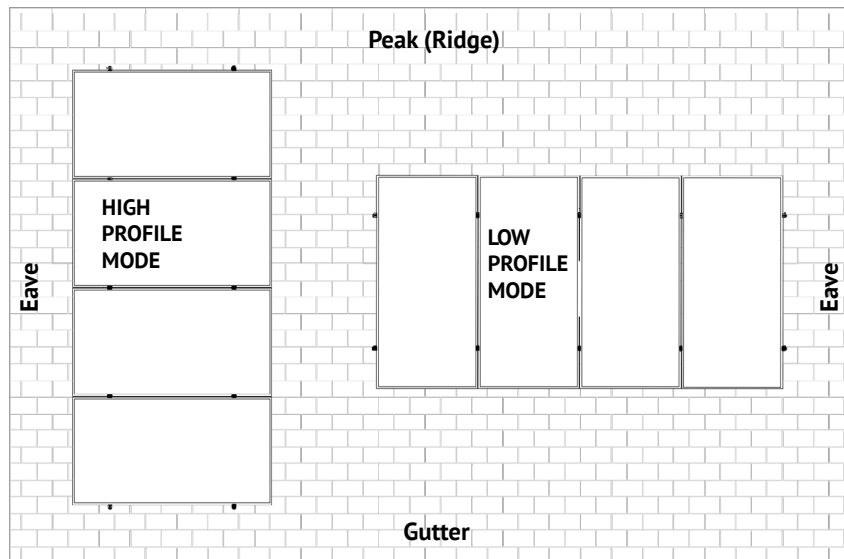
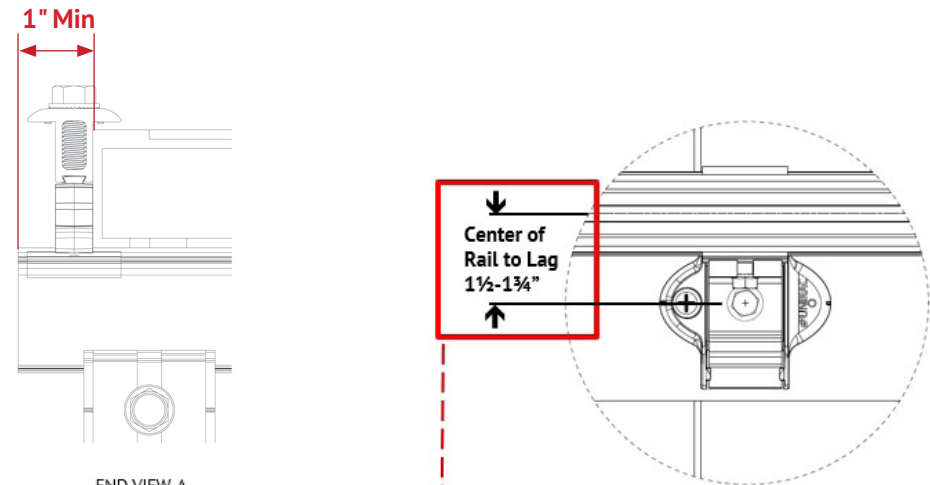

EXPANSION JOINT USED AS THERMAL BREAK

Expansion joints prevent buckling of rails or system connection failure due to thermal expansion. Determine location of expansion joints prior to installation of roof attachments and rails. To create a thermal expansion joint, provide a sufficient gap between rails for proper installation of end clamps and tooling to achieve required torque. A thermal break is required when a continuous length of spliced rails exceeds the maximum allowable lengths shown in the table to the right. For additional concerns on thermal breaks in your specific project, please consult a licensed structural engineer.

Rails in expansion joint configurations are considered cantilevered and must follow the cantilever rule on both sides of the expansion joint, which states that the maximum amount of rail that can be cantilevered is 1/3 the respective adjacent span. An expansion joint must not be spanned by a PV module. Installing a module over an expansion joint would defeat the goal of a thermal break and could result in damage to the array.

Bonding connection for splice used as a thermal break. Option shown uses two Ilco lugs (Model No. GBL-4DBT P/N GBL-4DBT - see product data sheet for more details) and solid copper wire. Optional grounding may be achieved through NXT UMOUNT MLPE & Lug Clamp. See Page 30.

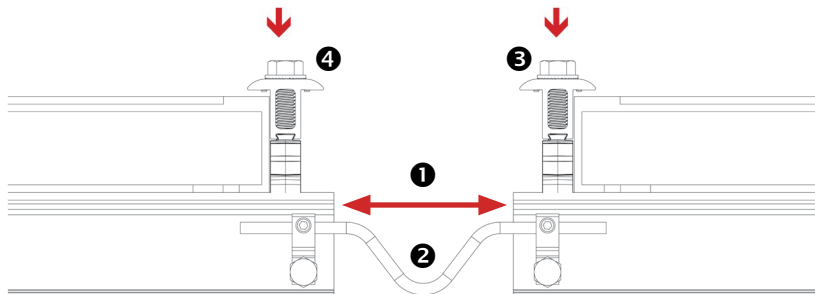

- ❶ Provide a sufficient gap between rails for proper installation of end clamps and tooling
- ❷ Connect rails with the bonding wire.
- ❸, ❹ Install end clamps. **See Page 23.**

ΔT (°F)	Maximum Continuous Length (ft.) of Spliced rails with Stronghold Attachments							
	FlashKit Attachment Span		Stronghold Attachment Span		Butyl Attachment W/#12 Screw		Butyl Attachment W/#14 Screw	
	48"	72"	48"	72"	48"	72"	48"	72"
0-40	100	126	92	114	76	90	84	102
40-50	92	114	84	102	68	78	68	90
50-60	84	102	76	90	60	78	68	78
60-70	76	90	68	78	52	66	60	66
70-80	68	90	60	78	52	60	52	66
80-90	68	78	60	66	44	54	52	60
90-100	60	78	52	64	44	48	52	54
100-120	60	66	52	53	40	40	44	45
120-140	52	57	44	45	34	34	36	39

The values displayed are the maximum allowed rail length, in feet, without a thermal break. If your span is less than 48" or using NXT UMOUNT HD rail, refer to the NXT UMOUNT Design & Engineering Guide for max lengths of continuous rail before a thermal break is required.

Determine the maximum rail temperature difference (ΔT) between the time of installation and the extreme high or low temperature. The Extreme Annual Design Conditions table at the following URL can be used as a reference when determining ΔT . <http://ashrae-meteo.info/>. The installer is responsible for determining the maximum temperature difference (ΔT) used to establish the maximum rail length.

As spans increase, so does the maximum reaction force that the rail exerts on the L-foot. Ensuring that the Maximum Reaction Forces do not exceed the shear capacity of the roof connection. See NXT UMOUNT Design & Engineering Guide for corresponding reaction forces.

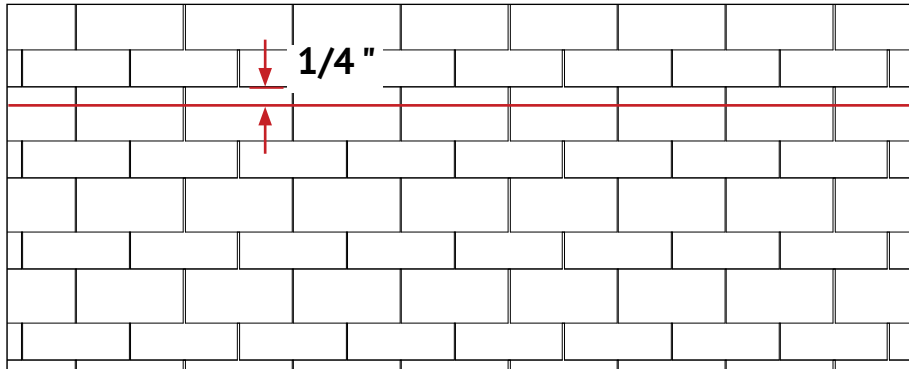

MARK ARRAY LOCATION:

Clean roof surface of dirt, debris, snow, and ice. Mark array location and determine roof attachment locations based on array layout. Snap chalk lines to mark each row of roof attachment points. On shingle roofs, snap lines 1/4" below upslope edge of shingle course. Locate rafters and mark at intersection of attachment lines. Attachment spacing determined per Design and Engineering Guide or project specific U-Builder Engineering Report .

PRO TIP

Install the attachment within 1/4" of the chalkline to allow the rail to slide freely in the rail clamp.

WARNING

- To maintain butyl flashing performance, Unirac does not recommend installing when ambient and/or roof temperatures are below 5°F or above 180°F.
- Stronghold Butyl must be installed on a clean, dry surface to ensure flashing integrity.

NOTE:

- Stronghold Butyl is designed for use on Asphalt Shingle, Rolled Comp, EPDM, TPO, Polyethylene, Polypropylene, ABS, and Metal Roofs (including Galvalume, painted steel, and galvanized).
- Pilot holes are not necessary to be drilled for self-drilling screws. If holes are drilled to identify the rafter, they should be backfilled with sealant before installing the attachment.
- Stronghold Butyl attachments are designed for slopes ranging from 0 to 90-degrees. For installations over 45-degrees, contact Unirac engineering for design guidance.

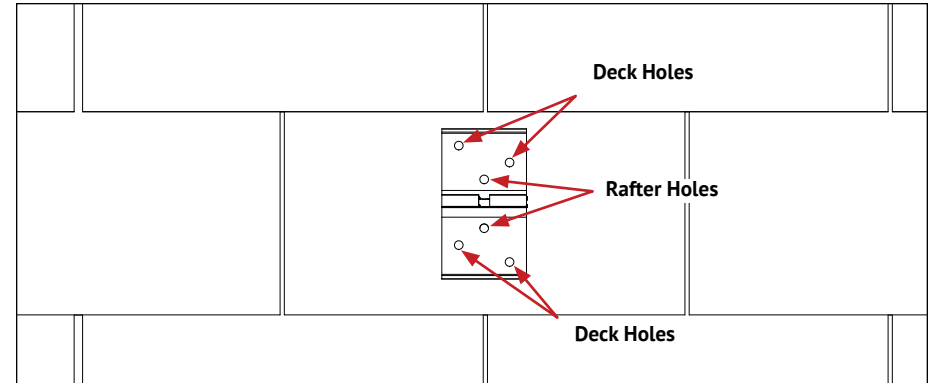

PLACING STRONGHOLD ATTACHMENT WITH BUTYL BASE:

Identify the position of the attachment to install before peeling the release paper. Ensure that the attachment lands on a flat surface. If the surface at the location of the attachment is uneven, add butyl patches to flatten the surface.

Note:

- Use rafter holes to install attachment on the rafter.
- Use all six holes to install attachment on the deck.

CAUTION

Do not peel the release paper from the butyl on attachment before identifying the position of attachment to install.

WARNING

Installing attachment on uneven surfaces, shingle gaps or overlaps, creates a risk for water leakage due to gap created between the adhesive and roof surface.

Note:

See Page 11 for instructions on placing extra butyl pads or contact Unirac team for further information.

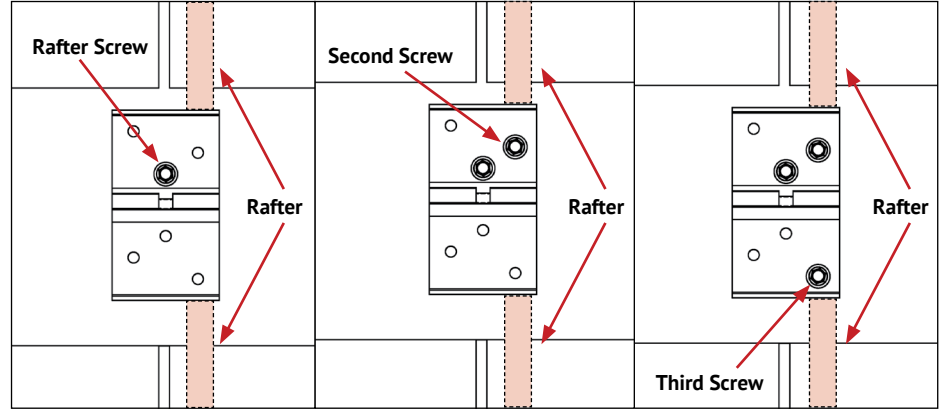
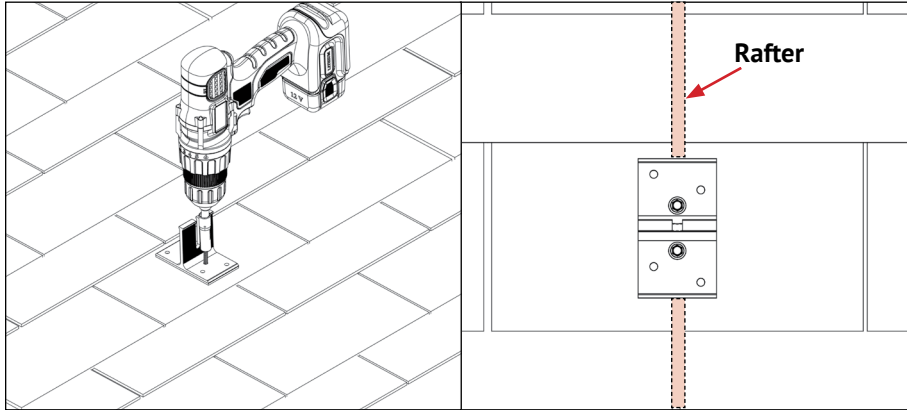

INSTALLING STRONGHOLD ATTACHMENT WITH BUTYL BASE TO RAFTER:
Peel-off the release paper from the underside of the attachment and place stronghold attachment with butyl over rafter location and align edge of mount with horizontal chalk line. Secure mount with the two (2) provided rafter screws in the rafter holes of the attachment.

Note:
Ensure to use drill extension or deep socket tool for installing rafter screws.

CAUTION

- To determine if the screw is engaging the rafter, there should be resistance to driving the screw through the entire length. If the screws do not properly engage the rafter, refer to the pro tip mentioned.
- It is recommended to begin installation with the screws on the upslope side of the attachment and continue installing the screws on the downslope side of the attachment for best fit.

WARNING

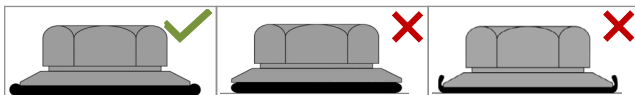

Do not over-torque the structural screw.
When proper torque is applied, the EPDM washer should slightly expand out from the sides as shown in the image.

PRO TIP:
If you miss the rafter while driving the first screw and the rafter is on the edge of the attachment, then follow the steps below:

1. Install a second screw into the adjacent hole that is closest to the rafter center.
2. If the second screw hits the rafter, install the corresponding third screw and complete the installation.
3. If three or more screws miss the rafter, then follow the direct to deck installation procedure and reduce the attachment spans as per Unirac direct-to-deck recommended spans for roof attachment.

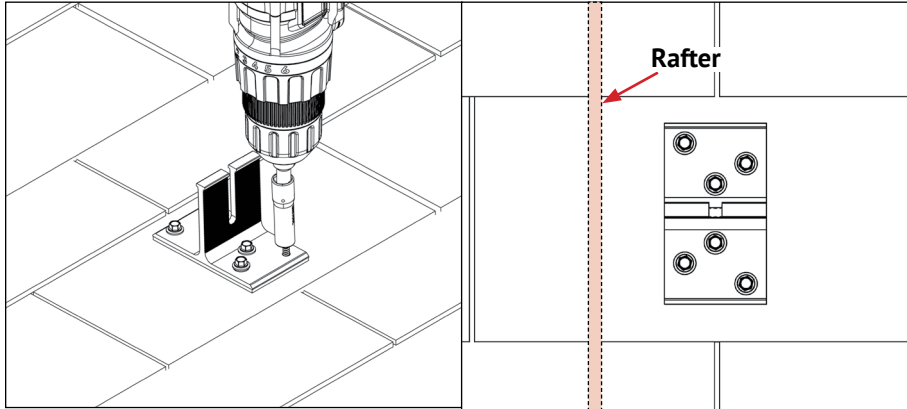

INSTALLING STRONGHOLD ATTACHMENT WITH BUTYL BASE TO DECK:

When installing the attachment to the decking instead of the rafter (direct-to-deck), install 4 additional screws on the remaining screw holes on the attachment

Note:

- Additional deck screws are NOT included in the KIT. Must be purchased separately.
- Maintain stock of additional deck screws from Unirac Kits in case of direct-to-deck installation.

CAUTION

1. Allowable attachment spans may change for direct-to-deck applications.
2. Unirac recommended spans are only valid with Unirac supplied screws.

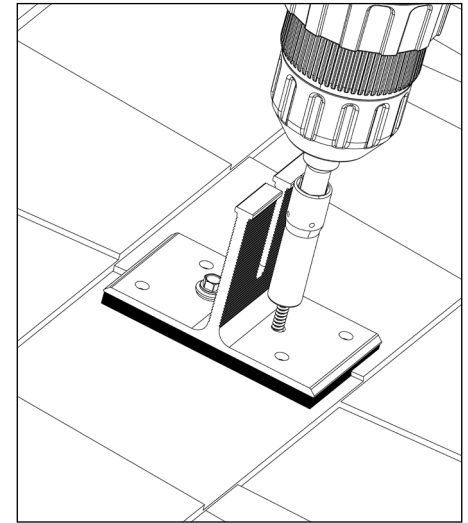
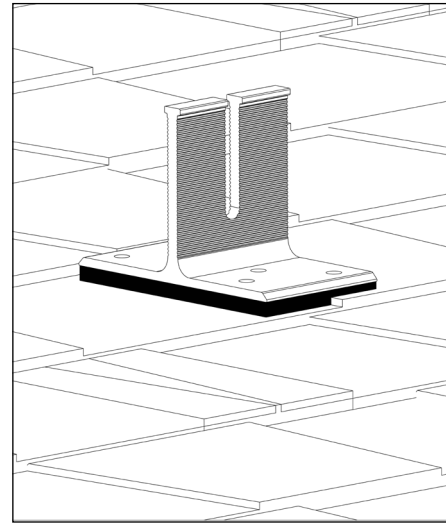
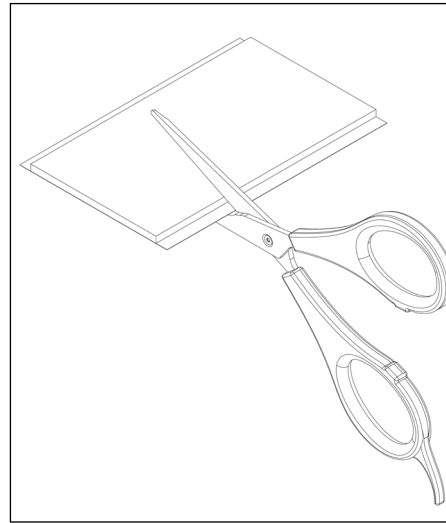
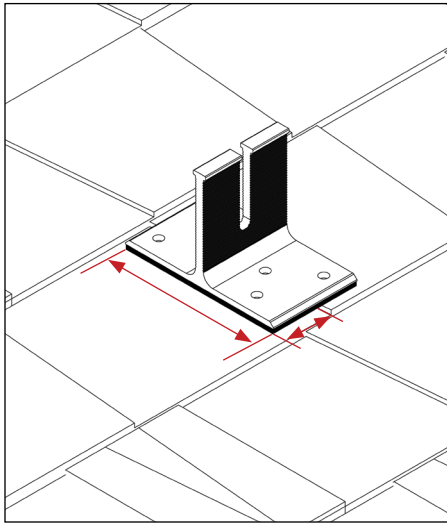

INSTALLING STRONGHOLD DTD BUTYL ATTACHMENT OVER SHINGLE OVERLAP

If the attachment falls over a shingle overlap, level the surface by following below steps:

- Measure the attachment overhang.
- Cut the butyl pads to required size.
- Stack extra butyl pad layers as necessary to level the roof and place the attachment.
- Begin installation with the screws on the upslope side of the attachment and continue to install the screws on the downslope side of the attachment.

PRO TIP

- If the attachments overlap from one shingle course to the next shingle course in a rail-based system, reposition the attachment by moving up or down the shingle course along the same rafter line to avoid butyl layering.
- Additional butyl layering is not required while installing attachment over a gap in the same shingle course

Note:

- Extra butyl pads are **NOT** included in the KIT.
- Pre-stock with extra butyl pads from Unirac Kits in case installation is required over overlap or gap.



Installing attachment on uneven surfaces, shingle gaps or overlaps, creates a risk for water leakage and rail clamp misalignment due to gap created between the adhesive and roof surface.

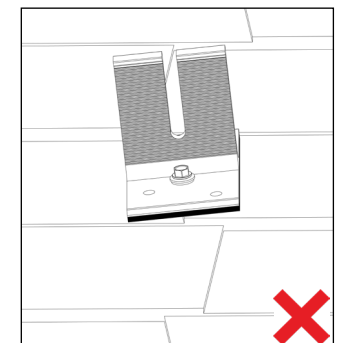
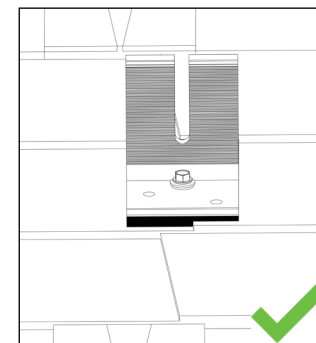

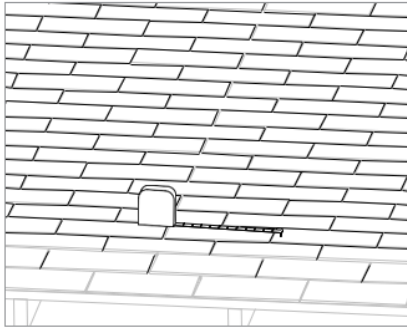

MARK ARRAY LOCATION:

Mark array location and determine roof attachment locations based on array layout. Snap chalk lines to mark each row of roof attachment points. On shingle roofs, snap lines 1-3/4" below upslope edge of shingle course. Locate rafters and mark at intersection of attachment lines. Attachment spacing determined per Design and Engineering Guide or project specific U-Builder Engineering Report .

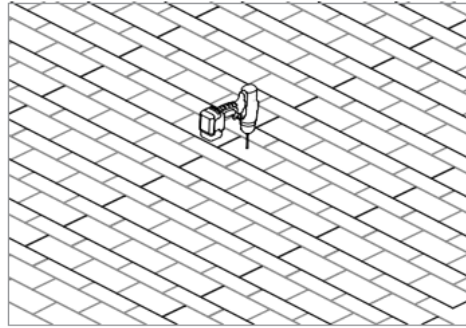

DRILL PILOT HOLES: Drill a 7/32" pilot hole at each roof attachment. Clean roof surface of dirt, debris, snow, and ice. Fill each pilot hole with sealant.



In case of missing a rafter, fill in the pilot hole with sealant.

Pro Tip:

Drill pilot holes within 1/4" of chalkline to allow rail to slide freely in Rail Clamps. See Page 17.

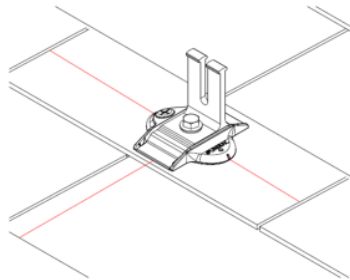

INSTALL STRONGHOLD ATTACHMENT BASE:

Place the Stronghold attachment base assembly over the pilot hole. Align indicator marks of mount with chalk line. Drive lag bolt until mount is held firmly in place. The EPDM washer should compress and expand slightly beyond the outside edge of the steel washer when the proper torque is applied.

Note: Rail clamp can be installed in four orientations. See Page 15 for a detailed view.

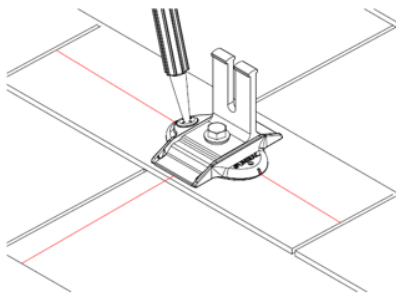

SEAL:

Insert tip of UNIRAC provided sealant into port. Inject until sealant exits vent. Follow sealant manufacturer's instructions and cold weather application guidelines, if applicable.

Note:

USE ONLY UNIRAC APPROVED SEALANTS: Chemlink Duralink 50, Chemlink M-1, Geocel 4500, Geocel S-4 or SealBond SB-500. Follow sealant manufacturer's instructions and cold weather application guidelines.

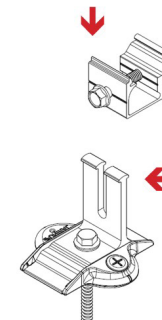

PLACE RAIL CLAMP ONTO L-FOOT:

Drop the rail clamp assembly into the open slot of L-Foot.



Do not tighten the rail clamp before putting in the rail.

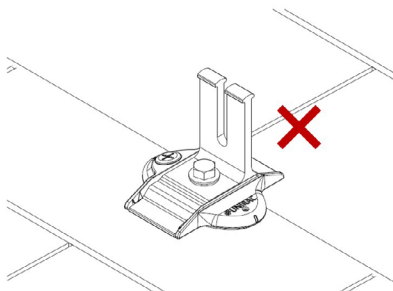

Avoid installing stronghold attachments across gaps or overlaps in roofing materials that are larger than 1/8 inch.

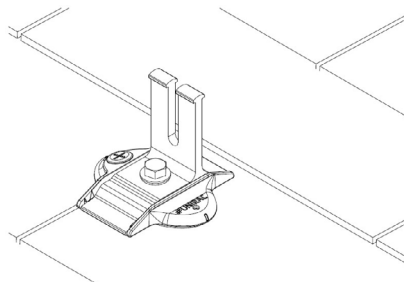

When installing the stronghold attachment over vertical joints, fill gap/joint with sealant between mount and upslope edge of shingle course.

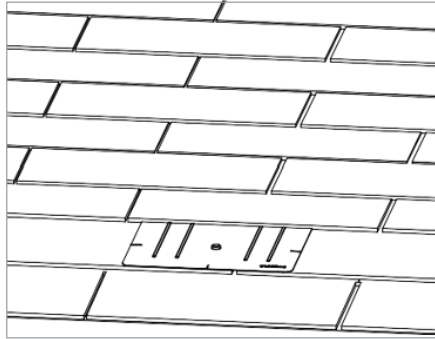

INSTALL FLASHKIT PRO FLASHING:

Add a U-shaped bead of roof sealant to the underside of the flashing with the open side of the U pointing down the roof slope. Slide the aluminum flashing underneath the row of shingles directly up slope from the pilot hole as shown. Align the indicator marks on the lower end of the flashing with the chalk lines on the roof to center the raised hole in the flashing over the pilot hole in the roof. When installed correctly, the flashing will extend under the two courses of shingles above the pilot hole.

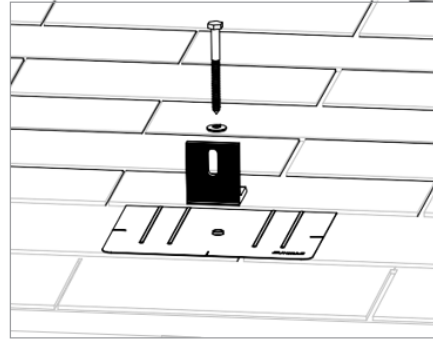

INSTALL L-FOOT: Fasten L-foot and flashing into place by passing the included lag bolt and pre-installed stainless steel-backed EPDM washer through the L-foot EPDM grommet, and the hole in the flashing, into the pilot hole in the roof rafter. Drive the lag bolt down until the L-foot is held firmly in place. The EPDM washer should compress and expand slightly beyond the outside edge of the steel washer when the proper torque is applied.

Note: FLASHKIT PRO L-FOOT can be installed in TWO orientations. See Page 16 for detailed view.

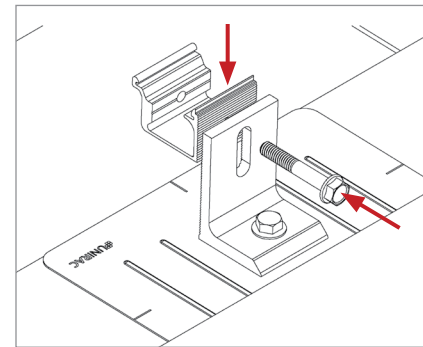

FIX RAIL CLAMP ONTO L-FOOT: Remove bolt from rail clamp. Place bolt through slot in L-foot and through hole in Rail Clamp. Partially thread bolt into rail clamp, leaving the bolt loose to accept the rail.

Note: Rail Clamp can be installed on any standard L-foot.

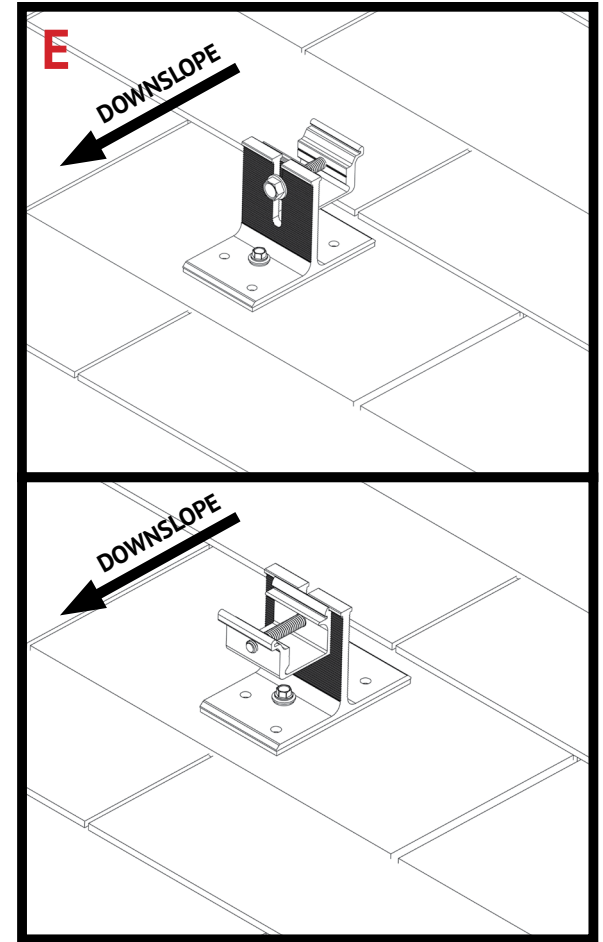
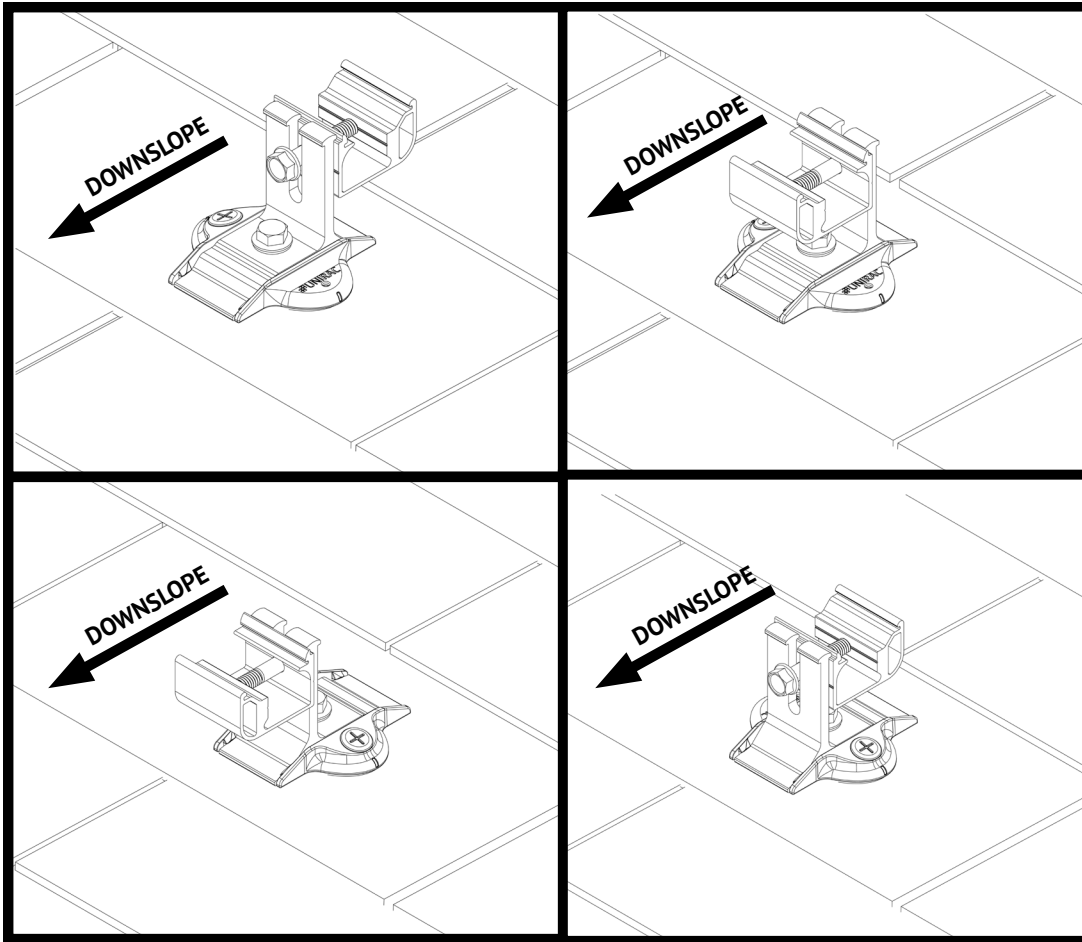

STRONGHOLD ATTACHMENT AND RAIL CLAMP ORIENTATIONS:

The Stronghold Attachment and Rail Clamp can be installed in any of four possible orientations, shown in images (A) through (D) above.

Note: For high snow loads, use orientations (C) or (D). Refer to NXT UMOUNT Design and Engineering Guide for specific requirements.

STRONGHOLD ATTACHMENT WITH BUTYL AND RAIL CLAMP ORIENTATIONS:

Stronghold Attachment with Butyl and Rail Clamp can be installed in either orientation shown in image (E) and (F) above.

Note: For high snow loads, use orientation (F). Refer to NXT UMOUNT Design and Engineering Guide for specific requirements.

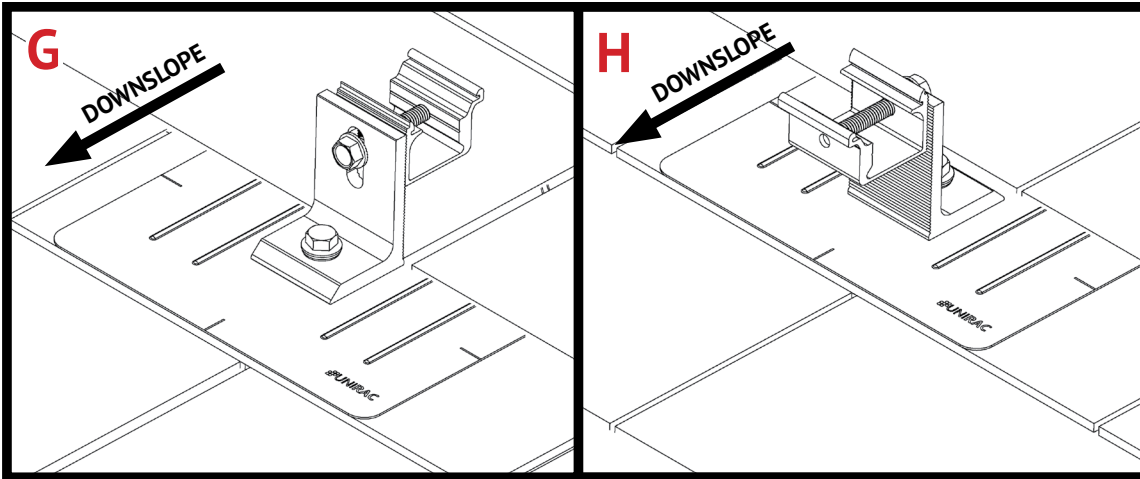

FLASHKIT PRO L-FOOT AND RAIL CLAMP ORIENTATIONS:

Flashkit Pro L-foot and Rail Clamp can be installed in either orientation shown in image (G) and (H) above.

Note: For high snow loads, use orientation (H). Refer to [NXT UMOUNT Design and Engineering Guide](#) for specific requirements.

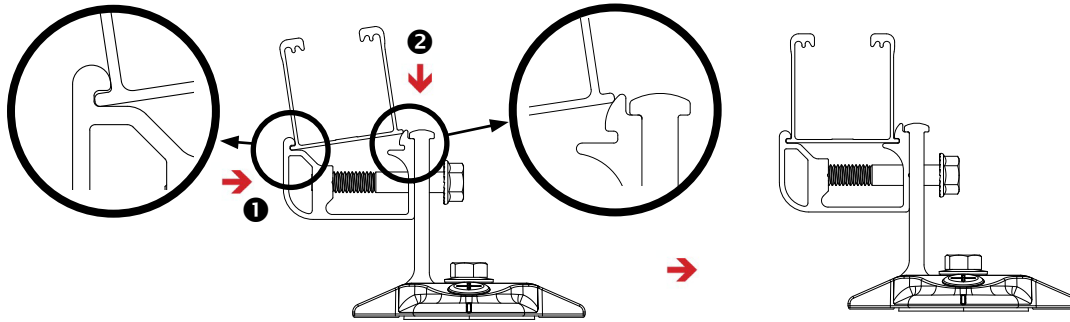

POSITION RAIL ONTO RAIL CLAMP:

With the bolt in the pre-assembled (loose) position, Insert the rail flange on one side of the clamp groove. Then click-in the other side of the rail into the clamp groove.



Do not tighten the rail clamp before putting in the rail.

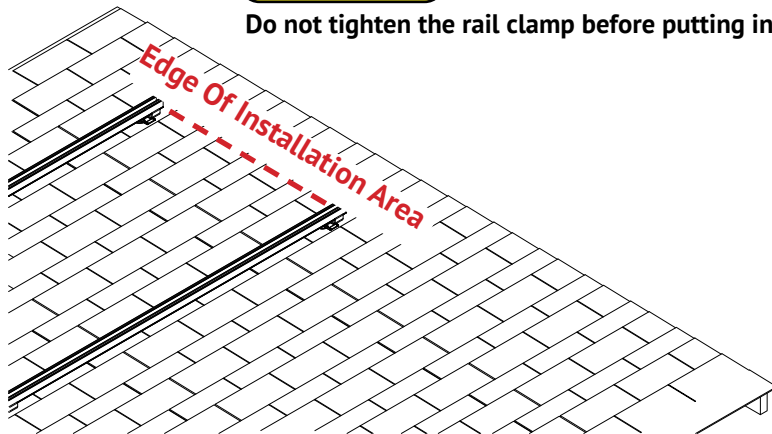

ALIGN RAILS: Align one pair of rail ends to the edge of the installation area. The opposite pair of rail ends will overhang installation area. Do not trim them off until the installation is complete. Install the first module at the aligned end. If the rails are parallel to the rafters, the aligned end of the rails should face the lower edge of the roof. Securely tighten all hardware after alignment is complete.

Mount modules to the rails as soon as possible. Large temperature changes may bow the rails within a few hours if module placement is delayed.

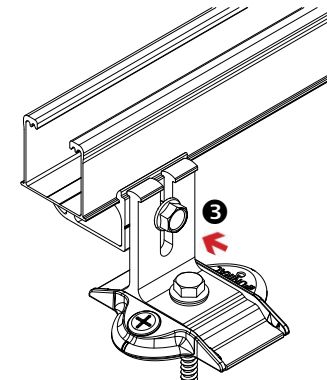

TIGHTEN RAIL ONTO RAIL CLAMP :

Adjust the rail height as needed until rail alignment is complete and tighten bolt.

TORQUE VALUE: 20 ft-lbs.

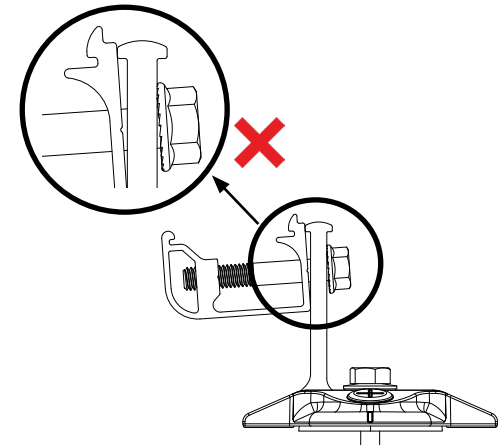

Rail clamp must be flush to the L-foot and positioned below the flange at the top of the L-foot.

SPLICE INSTALLATION (IF REQUIRED PER SYSTEM DESIGN)

If your installation uses NXT UMOUNT Rail Splice, attach the rails together either before installing the rail or after. Use marking on the splice for centering the connection. To install, slide the splice into the rail on each rail and drag it to the center of the marking. Tighten both bolts on each rail with an impact drill, pressing firmly until the bolt-head is flush against the splice and torqued to 15 ft-lbs. Installation is complete when the bonding hardware penetrates the opposite side of the rail, and the assembly torque is achieved.

①, ②, ③ are the steps of installation.

TORQUE VALUE: 15 ft-lbs. Do not use Anti-Seize.

CAUTION

- If assembling splice directly on roof, take care to prevent bolts from penetrating roof covering.
- While installing the splice, ensure either of the rails is not offset from the center marking.

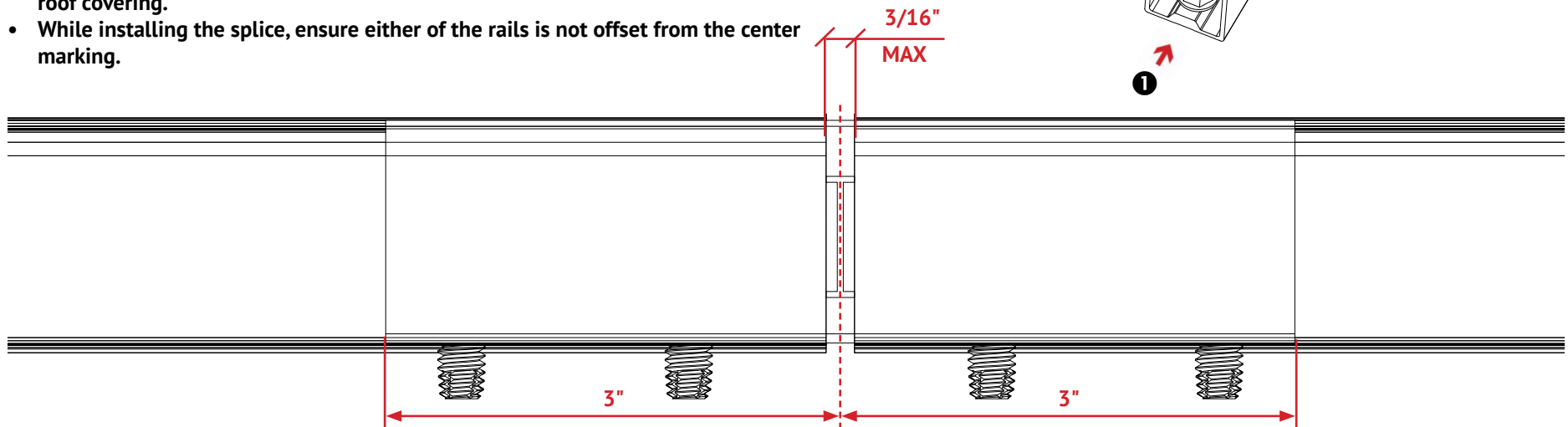
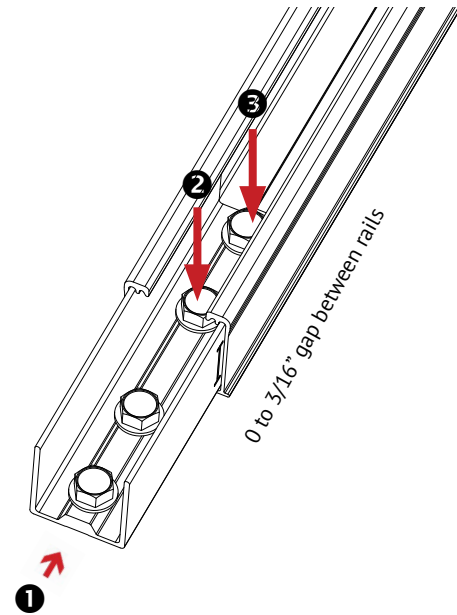

- Note:**
1. Maximum gap between rails should not exceed 3/16" at splice connection
 2. Splice certified for single-use only

CAUTION

The Combo Clamp can be installed over the splice but cannot be centered at the gap of two rails due to placement of bonding features in the rail nut. Place Combo Clamp 1/4" to the left or right of the rail gap.

CAUTION

- Do not install the Combo Clamp directly over the rail gap.
- The bonding features in the rail nut will not engage properly at the gap.
- Position the Combo Clamp at least 1/4 inch to the left or right of the rail gap.

NOTE: This caution is also applicable when we use HD Rail.

Refer to *Page 23* for combo clamp installation instructions.

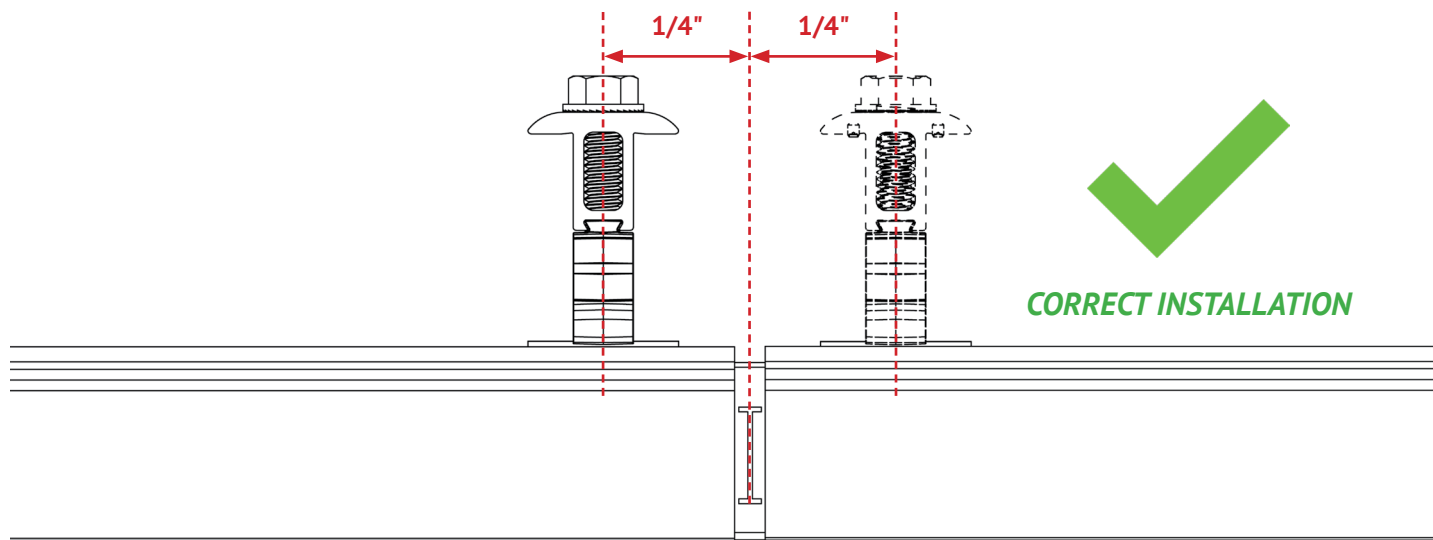
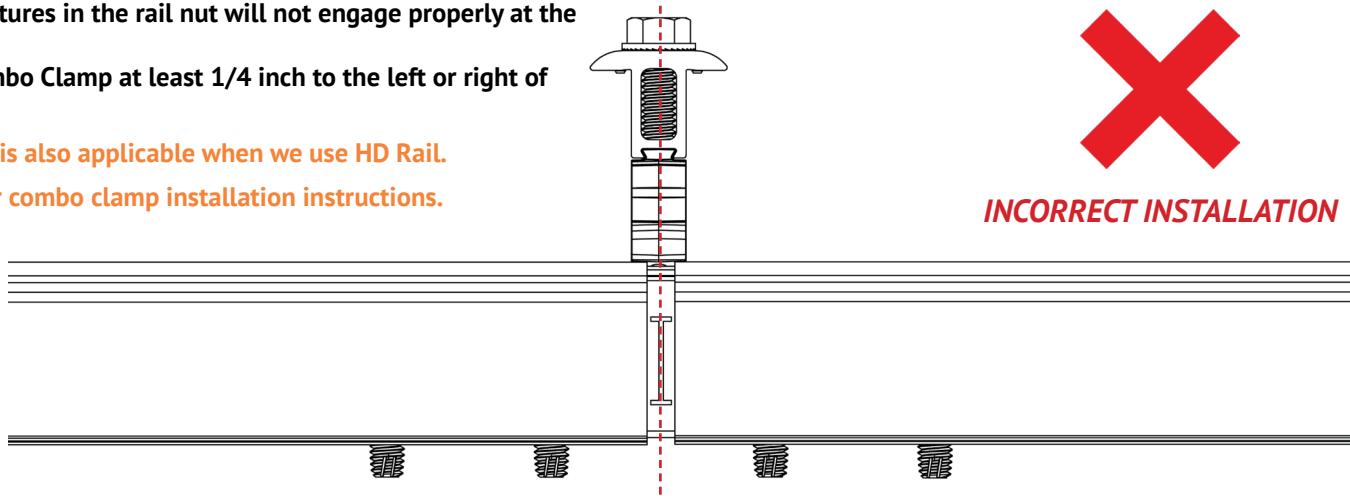

HD SPLICE INSTALLATION (IF REQUIRED PER SYSTEM DESIGN)

If your installation uses NXT UMOUNT HD Rail Splice, attach the rails together either before installing the rail or after. Use marking on the splice for centering the connection. To install, slide the splice into the rail on each rail and drag it to the center of the marking. Tighten both bolts on each rail with an impact drill, pressing firmly until the bolt-head is flush against the splice and torqued to 15 ft-lbs. Installation is complete when the bonding hardware penetrates into the rail's closed hollow section, and the assembly torque is achieved.

①, ②, ③ are the steps of installation.

TORQUE VALUE: 15 ft-lbs. Do not use Anti-Seize.



While installing the splice, ensure either of the rails is not offset from the center marking.

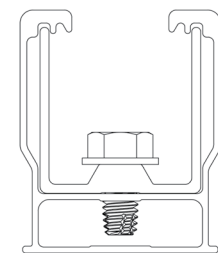
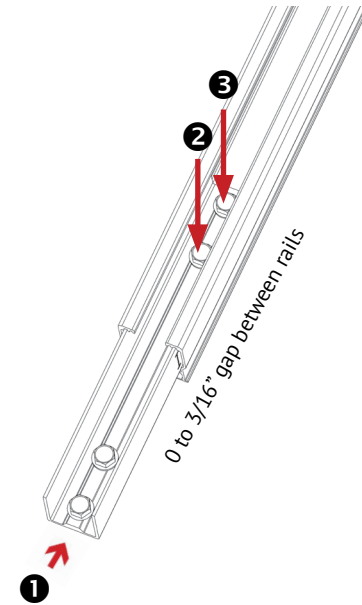
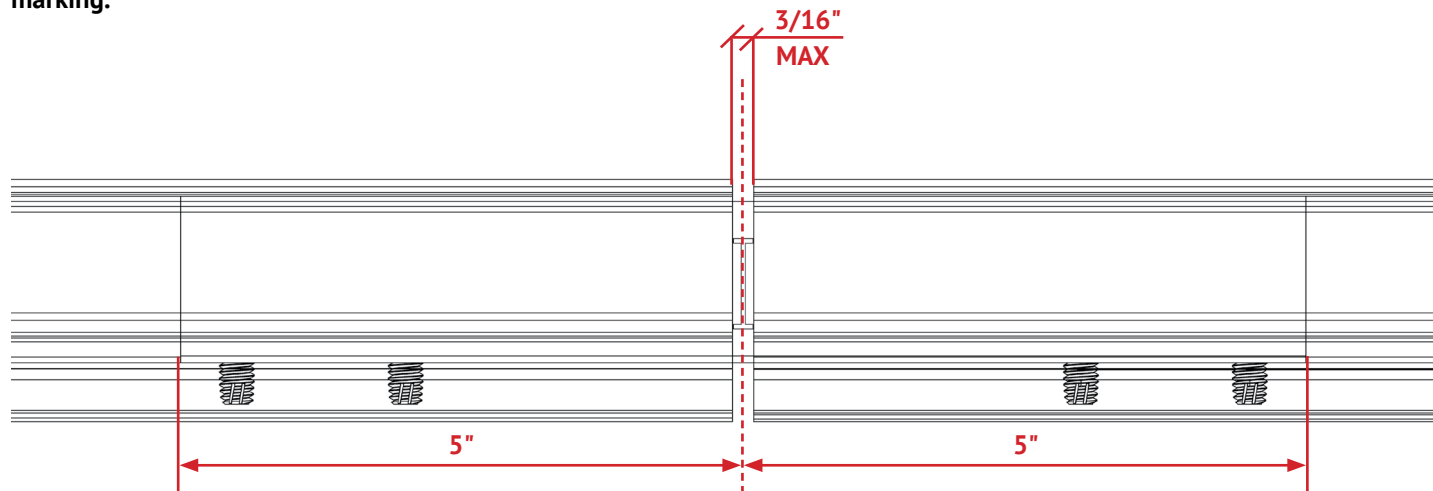

SIDE VIEW

Note:

1. Maximum gap between rails should not exceed 3/16" at splice connection
2. Splice certified for single-use only

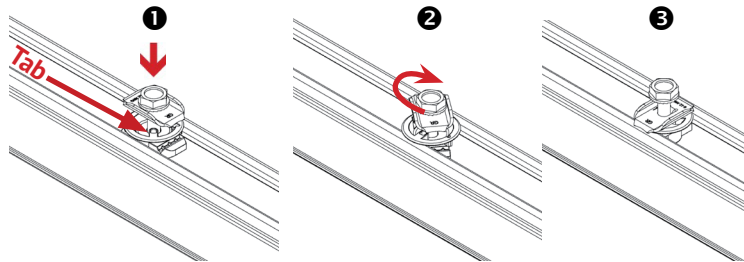

INSTALL MLPE & GROUNDING LUG: Insert the T-nut into the rail by holding the plastic cone's tabs with your thumb and middle finger. Rotate the grounding lug 90 degrees in a clockwise direction on the rail and release it when aligned with the rail. Ensure that the T-nut is engaged in the rail profile.

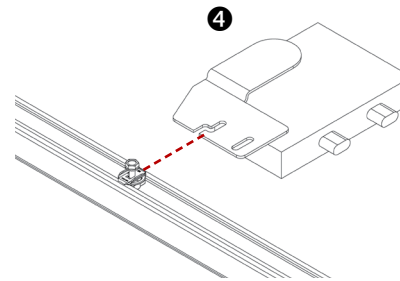

INSTALL MICROINVERTER: Place the microinverter between the ground plate and the rail. Engage it to bolt.

NOTE: MLPE & GROUNDING LUG is single use only

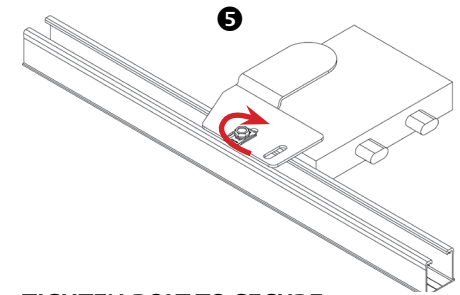

TIGHTEN BOLT TO SECURE:

TORQUE VALUE: 10 ft-lbs.

Quick Tip: To remove the MLPE & Grounding Lug from the rail, hold the plastic cone's tabs with your thumb and middle finger. Rotate anticlockwise by pressing downward.

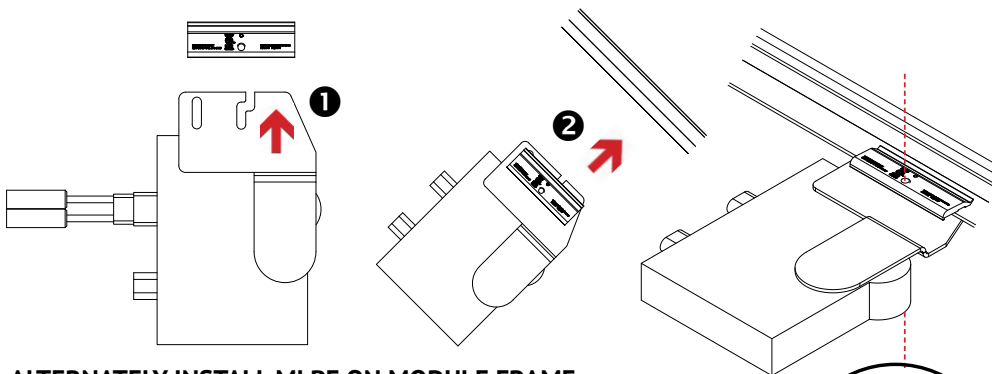

ALTERNATELY INSTALL MLPE ON MODULE FRAME: Engage MLPE & mount onto module frame flange and tighten bolt.

TORQUE VALUE: 20 ft-lbs.

Note: Refer to Unirac MLPE Mount Installation Manual for details at <https://unirac.com>



WARNING
Ensure Copper does contact Aluminum to avoid corrosion.

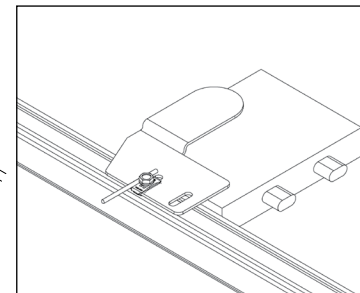

NOTE: MLPE & Grounding Lug can be used simultaneously to mount MLPE device and grounding wire.



CAUTION
Ensure the copper grounding wire is on top of ground plate and NOT in contact with rail or MLPE mounting plate.

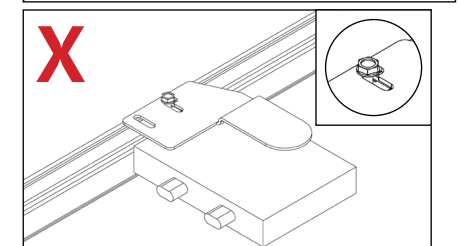
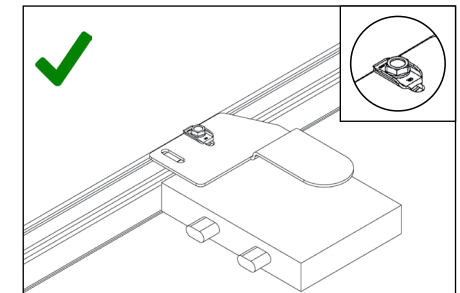

CAUTION
Ensure that grounding plate is always installed on the top of MLPE devices.

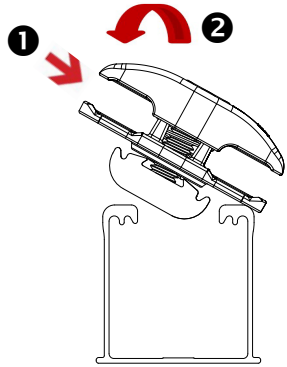

INSTALL NS WIRE MANAGEMENT CLIP:
 Insert the wire clamp assembly into the rail by placing one end of the rail nut into the rail and clip in the other end.

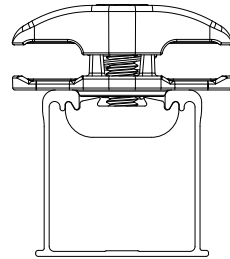

INSTALL NS WIRE MANAGEMENT CLIP:
 Ensure that the rail nut profile is seated in the rail profile.

Note: Wire clip can be oriented along the rail or perpendicular to secure wires between rails.

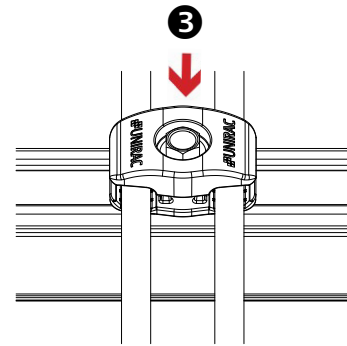

INSTALL NS WIRE MANAGEMENT CLIP:
 Insert the wires into the groove of wire clamp and tighten it down to the suggested torque value.

TORQUE VALUE: 3-7 ft-lbs.

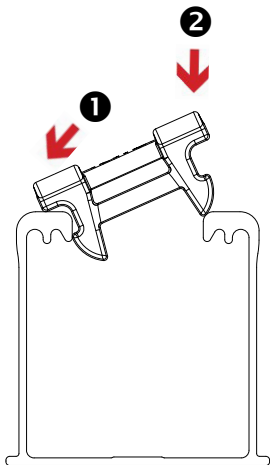

INSTALL WIRE MANAGEMENT CLIP:
 Wire clip retains the wire in the rail channel. Press fit the clip onto the rail flanges to install.

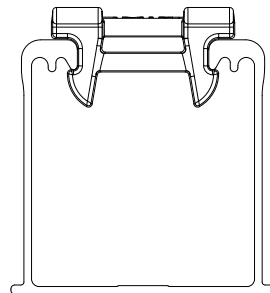

INSTALL WIRE MANAGEMENT CLIP:
 Ensure that the clip base is seated on the rail flange

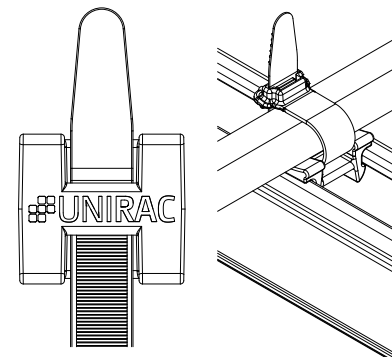

INSTALL WIRE MANAGEMENT CLIP:
 Use the wire tie to strap the wires down on the seater provided in the wire clip.

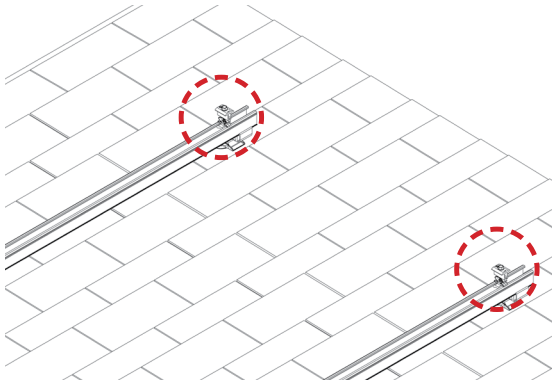

INSTALL COMBO (END) CLAMPS:

Install Combo Clamps starting at the aligned end of rails.

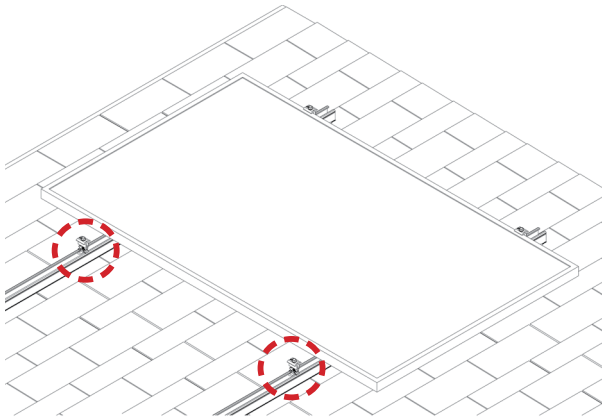

INSTALL COMBO (MID) CLAMPS:

Clamp assemblies may be positioned in rail near point of use prior to module placement.

Note: The clamps may be installed above splice locations.

PRO TIP

Press the clamp assembly slightly into the rail to allow for easy sliding of clamp in the rail.

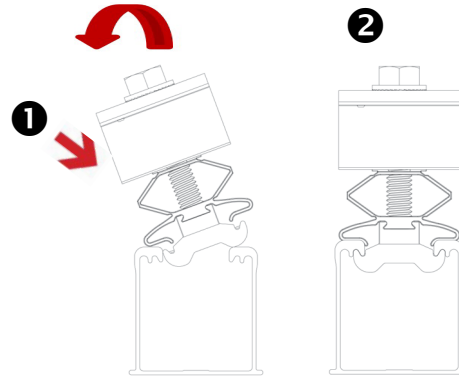

INSERT COMBO CLAMP:

Insert Combo Clamp from one side of the rail nut into the rail and click in the other side. Ensure that the rail nut profile is seated in the rail profile.

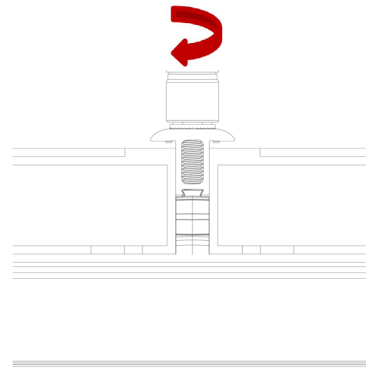

PLACE ADJACENT MODULE AGAINST CLAMPS:

Modules must be tight against clamps with no gaps. Tighten bolt to required torque.

TORQUE VALUE: 15 ft-lbs.

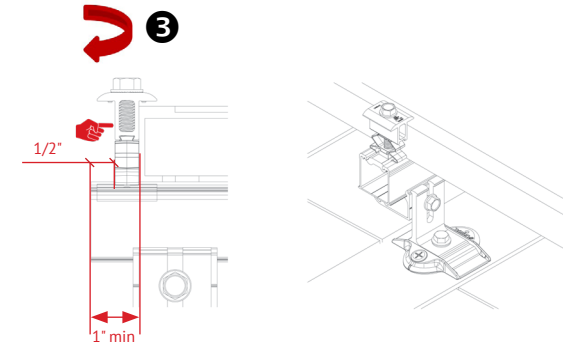

INSTALL END MODULE: Position first module onto rails and engage module frame with end clamps. Hold clamp in place against module while tightening bolt.

TORQUE VALUE: 15 ft-lbs.

Note: Ensure a minimum distance of 1" from the end of the module to end of rail.

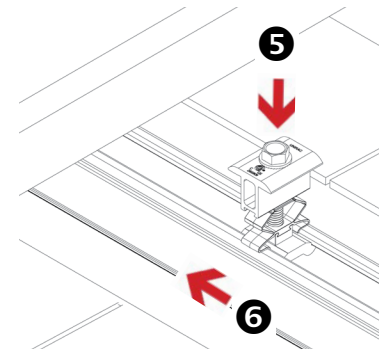

INSTALL REMAINING MODULES:

Proceed with module installation. Engage each clamp with previously positioned module.

Note: Combo clamps are capable of securing module frames whose thickness varies from 30mm to 40mm.

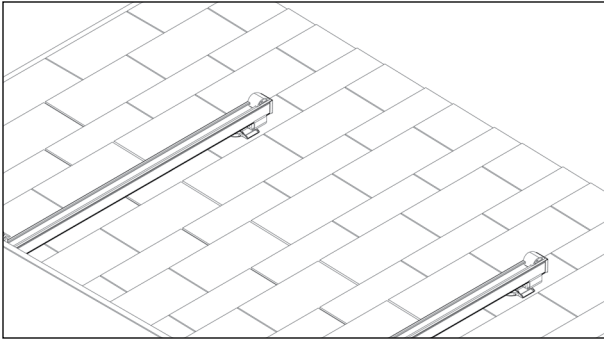

INSTALL MODULE END CLAMPS: The End clamp is supplied as kit with pre assembled end cap. The clamp should be installed on the rails prior to installing end modules.

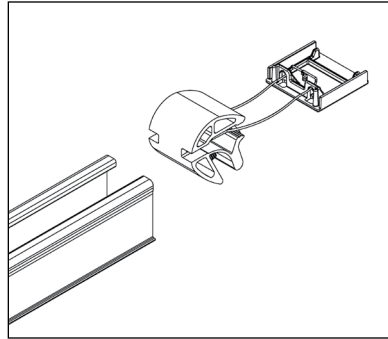

INSTALL END CLAMPS ON RAIL: Slide the end clamp assembly on to the rail by engaging grooves on both sides into the top flange of the rail.

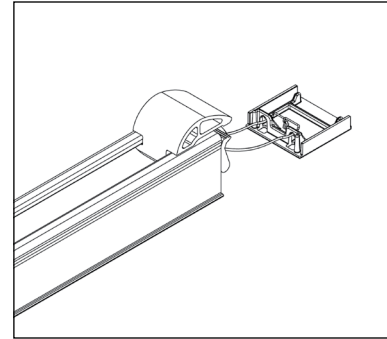

POSITION END CLAMPS: Slide the end clamp assembly onto the rail until the module return flange is cleared for placing the module

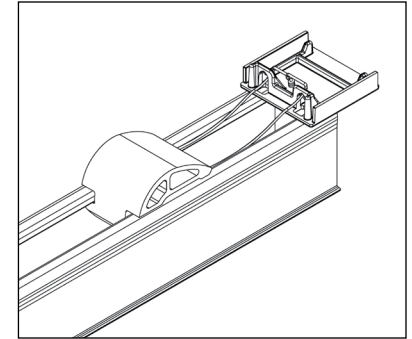

NOTE:
 To assist insertion of the clamp into the rail, hold the twist ties together and slide the clamp. Place the end cap on the rail flange for smooth gliding of the clamp to the required position.

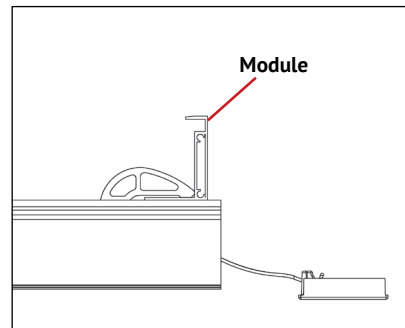
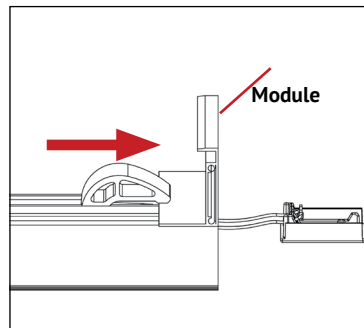
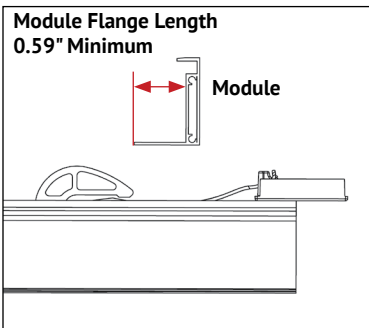

INSTALL FIRST MODULE:

Position first module onto rails with the clamp clear from the return flange of the module. Hold the end cap and drag the clamp onto the return flange of the module. Once the clamp is onto the return flange, drag the clamp till the edge of the clamp contacts the vertical wall of return flange.

Note:

- Ensure to use a drill extension or deep socket for installing the clamp bolt.
- Requires a minimum return flange length of 0.59" and thickness of 1-2 mm for Hidden Endclamp to secure the module.
- Installation method for the Hidden end clamp and end cap on the HD rail is similar to standard rail.

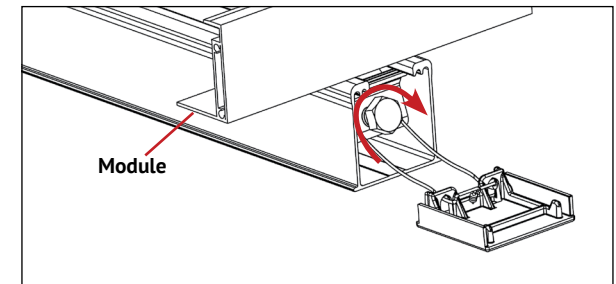

ENGAGE CLAMP: While holding the module in position and with the clamp in contact with the flange, tighten the end clamp bolt to the required torque.

Torque End Clamp bolt to 15 ft-lbs, No anti-seize



Ensure bolt is not over-torqued, use low torque setting on drill. If using an impact driver, stop rotation as soon as impact action of driver begins.

FOR HIDDEN CLAMP

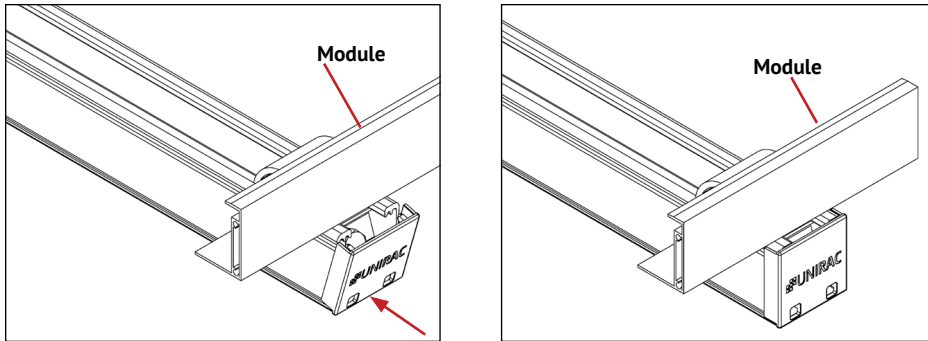

END CAP INSTALLATION:

To install the end cap, tuck in the twist tie in the rail beside the bolt. Position the cap on the edge of the rail and press the cap onto the rail.

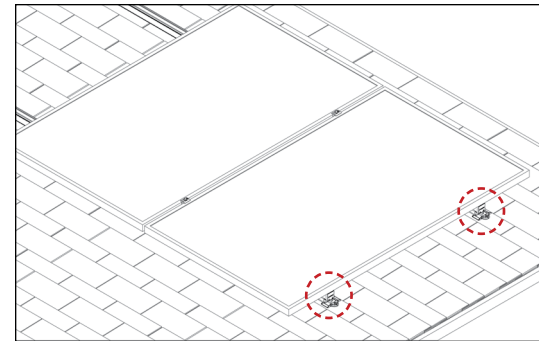

Pro Tip:

For best appearance, leave enough space for the bolt head while cutting the rail ends to perfectly snap fit the end cap.



Ensure the clamp bolt head does not protrude outside of the rail while cutting the rails for end cap installation.

Place module, flush with rail ends. The bolt head of the clamp must not protrude beyond the rail edge. Modules must be fully supported by rails and cannot overhang at the ends of rails.

FOR COMBO CLAMP

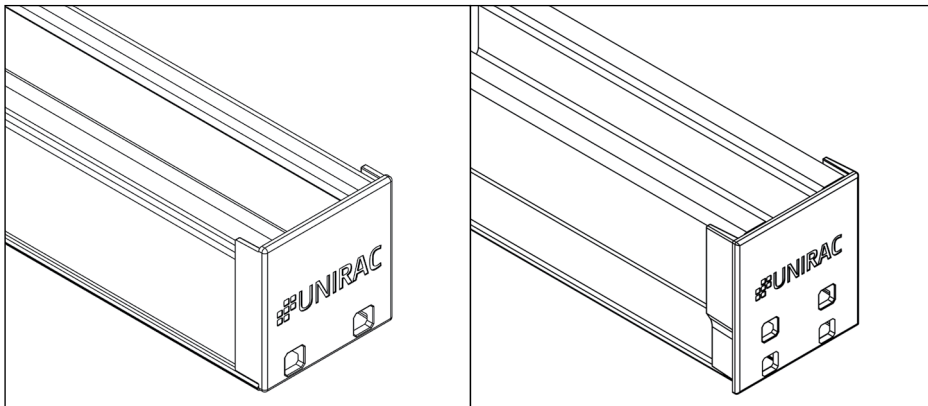

OPTIONAL END CAP:

To install the end cap, place the cap on the edge of the rail and press the cap onto the rail.

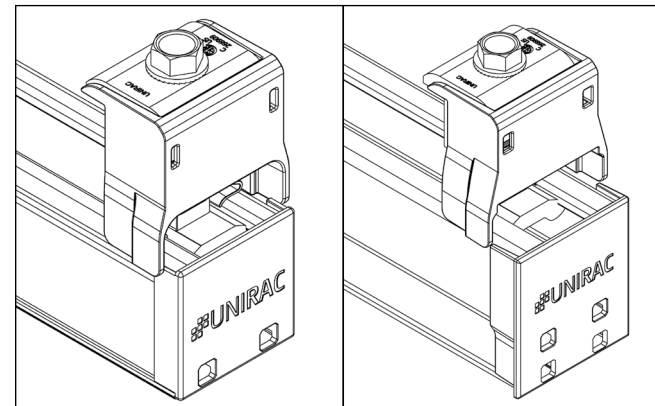

OPTIONAL COMBO CLAMP CAP:

To install the combo clamp cap, place the cap on the edge of the rail and press the cap onto the clamp.

S-5! COMPONENTS

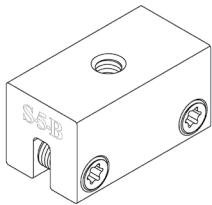

S-5-B



S-5-B Mini

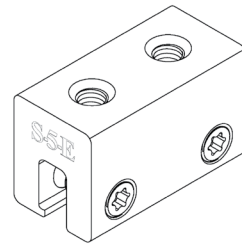

S-5-E

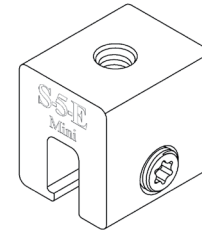

S-5-E Mini

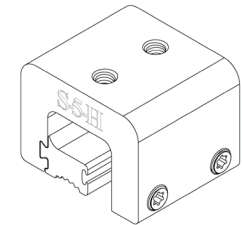

S-5-H

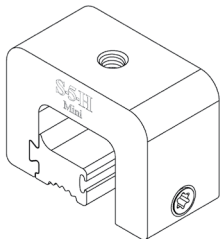

S-5-H mini

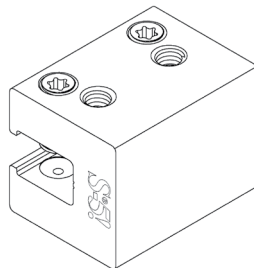

S-5-H90

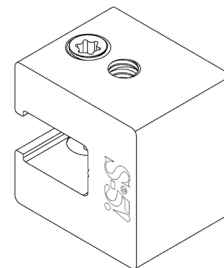

S-5-H90 Mini

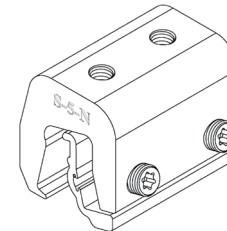

S-5-N

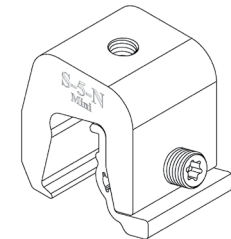

S-5-N Mini

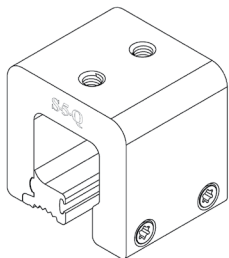

S-5-Q

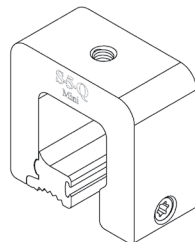

S-5-Q Mini

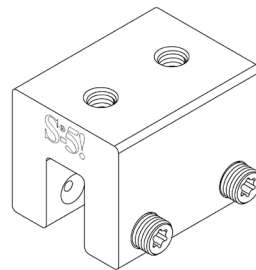

S-5-S

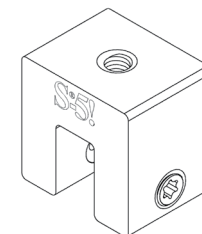

S-5-S Mini

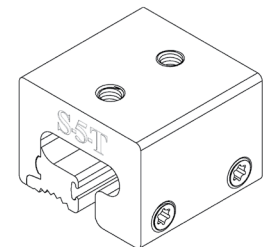

S-5-T

S-5! COMPONENTS

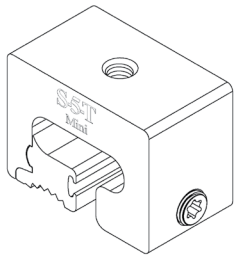

S-5-T mini

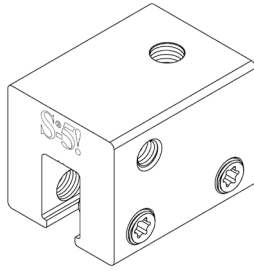

S-5-U

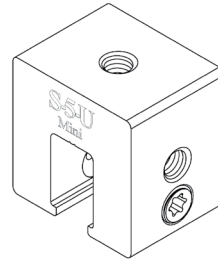

S-5-U Mini

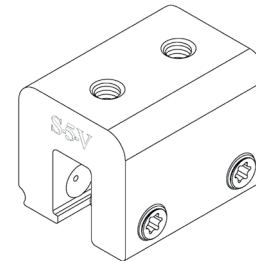

S-5-V

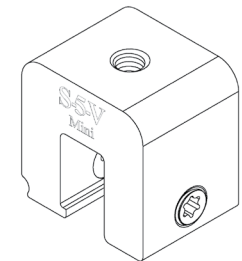

S-5-V Mini

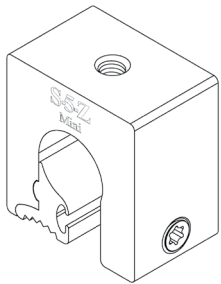

S-5-Z

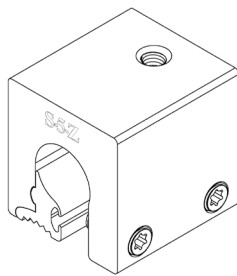

S-5-Z mini

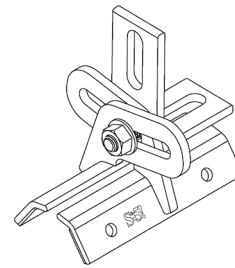

Protea Bracket

S-5! STANDING SEAM CLAMPS AND PROTEA BRACKET INSTALLATION

STEP 1: Follow the instructions provided on <https://buys-5.com/> for installing the S-5! standing seam clamps and Protea bracket to the metal roof.

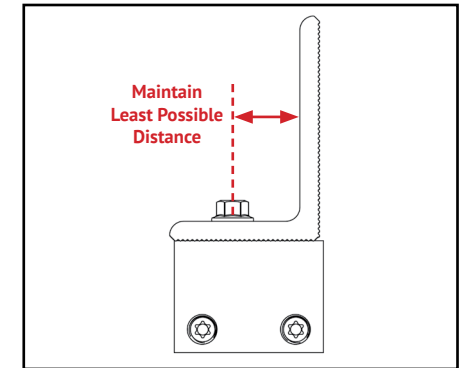
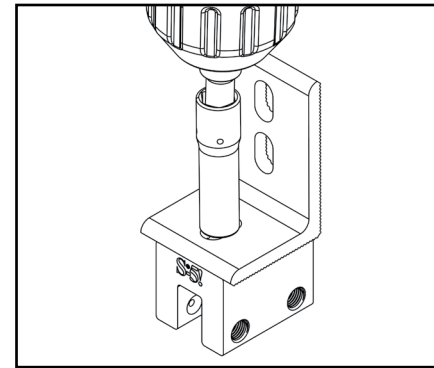
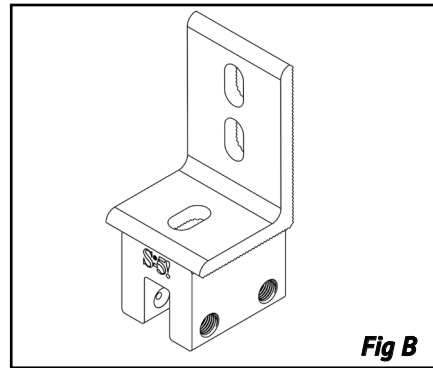
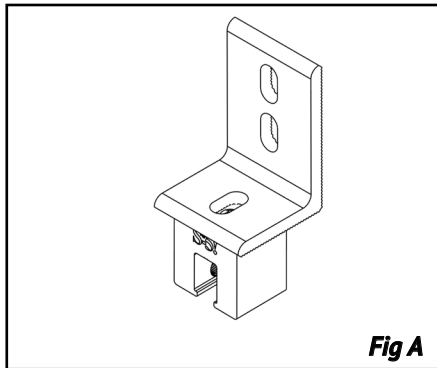

STEP 2: POSITION L-FOOT

Position L-foot on selected attachment clamp to align holes as shown in Fig A and Fig B.

STEP 3: SECURE L-FOOT

Use appropriate hardware required for the selected attachment to secure the L-Foot to the clamp.

Torque bolt to 13 ft-lbs

NOTE: It is recommended to maintain least possible distance between the upright leg of the L-foot and the bolt center.

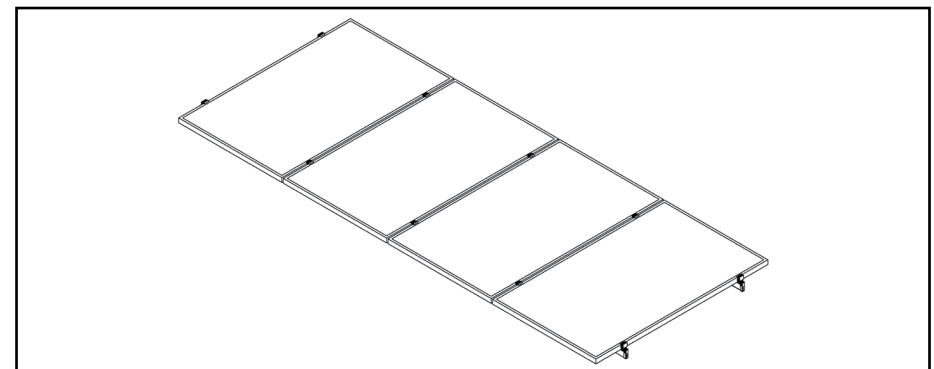
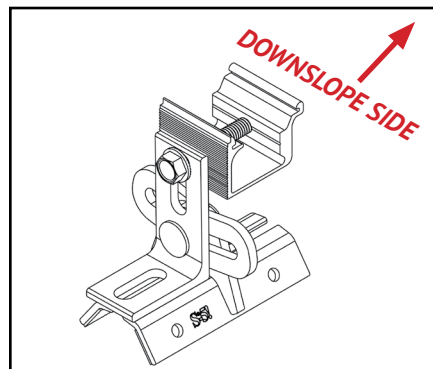
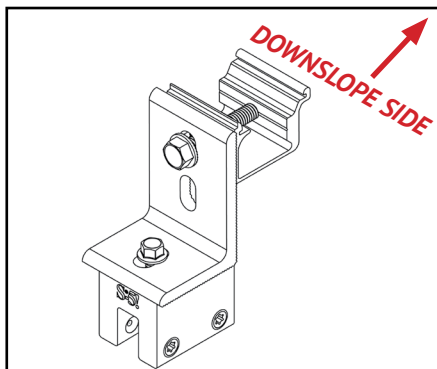

STEP 4: SECURE RAIL CLAMP TO L-FOOT OR PROTEA BRACKET

Follow the steps mentioned on **Page 14** to secure Rail to L-Foot or Protea Bracket

STEP 5: FINISH SYSTEM INSTALLATION

Finish NXT UMOUNT installation by following instructions provided in this manual from **Page 17** to **Page 25**. Ensure the system is properly grounded and bonded as per Bonding Connections & Grounding Paths section on **Pages 31-34**.



NXT METAL ROOF RAIL CLAMP INSTALLATION

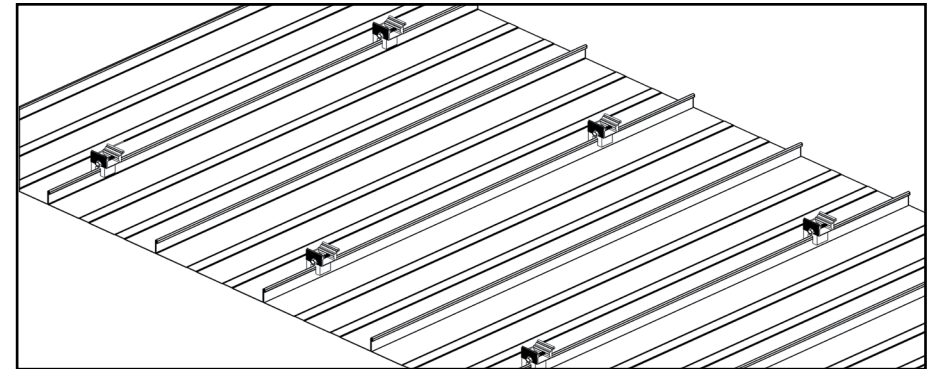
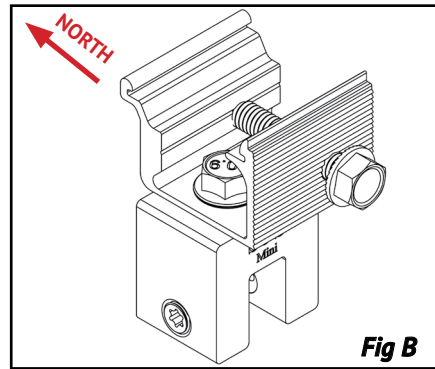
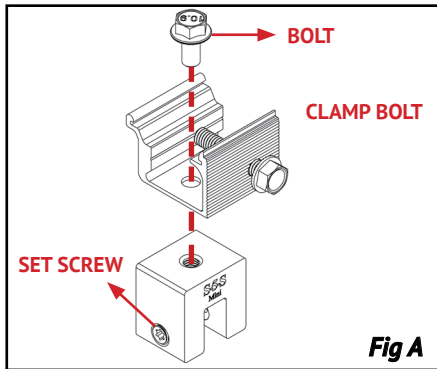

STEP 1: ASSEMBLE RAIL CLAMP AND ATTACHMENT

- Position the NXT metal roof rail clamp on the selected attachment to align holes as shown in Fig A
- Secure NXT metal roof rail clamp and attachment with the appropriate hardware required for the selected attachment
- Follow the torque specifications provided by attachment manufacturers.

PRO TIP: Assembling the roof attachments and NXT metal roof rail clamps is more convenient and efficient when performed on the ground than on the roof.

STEP 2: INSTALL ROOF ATTACHMENTS

Follow the instructions provided by the roof attachment manufacturer to secure the attachments to the metal roof.

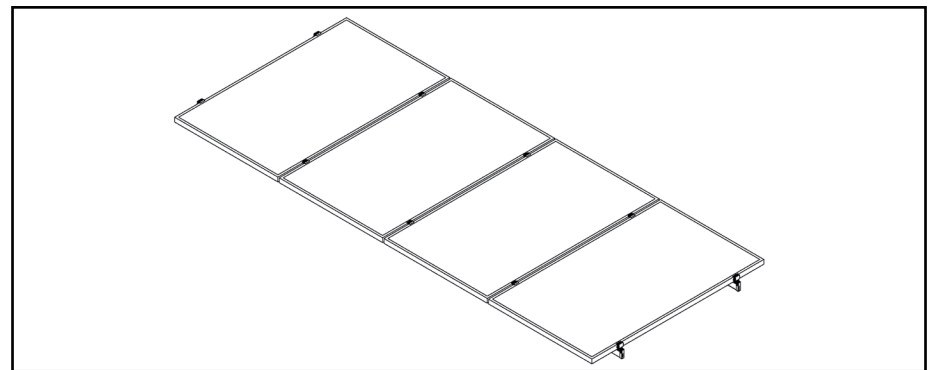

STEP 3: FINISH SYSTEM INSTALLATION

Finish NXT UMOUNT installation by following instructions provided in this manual from **Page 17** to **Page 25**. Ensure the system is properly grounded and bonded as per Bonding Connections & Grounding Paths section on **Pages 31-34**.

CAUTION

- After tightening the bolt, visually check that the rail clamp and roof attachment are flush and parallel.
- Ensure the bolt is positioned in between the rail clamp bolt and the roof attachment set screw.

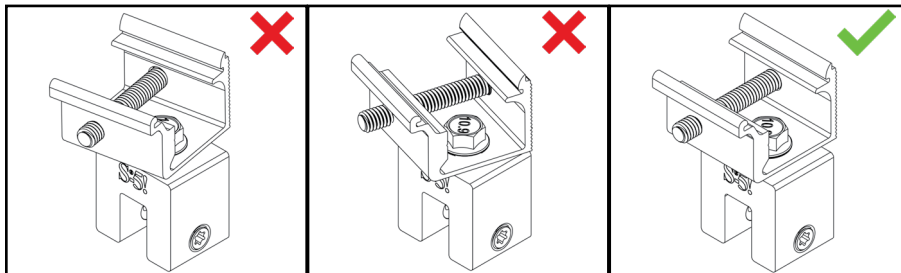

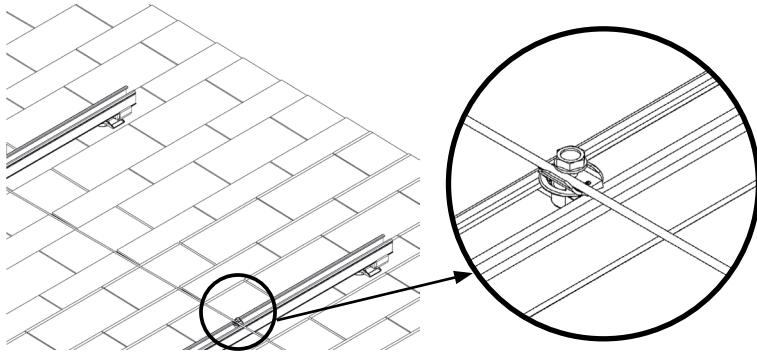

SYSTEM GROUNDING: Rails can be bonded using a MLPE & GROUNDING LUG (NULGMLP1), GROUND WEEBLUG #1 or ILSCO LAY IN LUG (GBL4DBT). At least one rail per row of modules in an array must be bonded to electrical ground. Each additional row of modules must be grounded with at least one rail lug per row or with a row-to-row bonding device listed here.

Note: See Page 7 for additional lugs required for expansion joints.

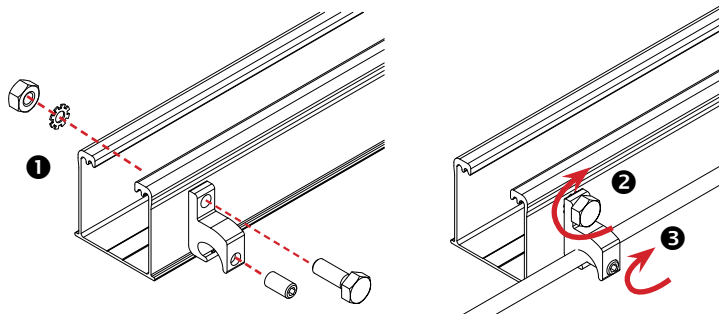

ALTERNATE SYSTEM GROUNDING WITH ILSCO LAY-IN LUG - UNIRAC P/N 008009P: Alternate Grounding Lug. Drill hole in rail 7/32" in diameter, deburr hole and bolt through one wall of rail.

BOLT TORQUE VALUE: 5 ft lbs.

TERMINAL TORQUE: 4-6 AWG: 35 in-lbs, 8 AWG: 25 in-lbs.



Ensure Copper does contact Aluminum to avoid corrosion.

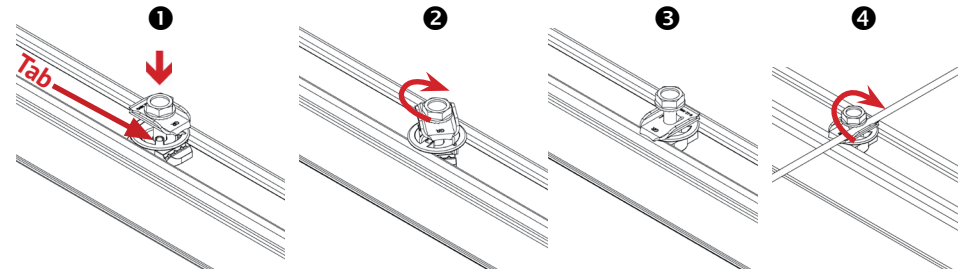

SYSTEM GROUNDING WITH MLPE & GROUNDING LUG: Insert the T-nut in the rail by holding the plastic cone's tabs with thumb and middle finger. Rotate the clamp 90 deg in clockwise direction in the rail and release when aligned with rail. Ensure that the T-nut is engaged in the rail profile. Place the grounding wire on top of the grounding plate on one of the side of the bolt, parallel to the grounding plate flanges. Ensure copper is not in contact with rail or MLPE plate surfaces. For stranded wire, Uniac recommends looping the wire around the bolt and leaving some insulation on the end of the wire to keep strands together. Tighten bolt to recommended torque.

TORQUE VALUE: 6-12 AWG SOLID COPPER: 10 ft lbs.

6-10 AWG STRANDED COPPER: 10 ft lbs

NOTE: MLPE & GROUNDING LUG is single use only

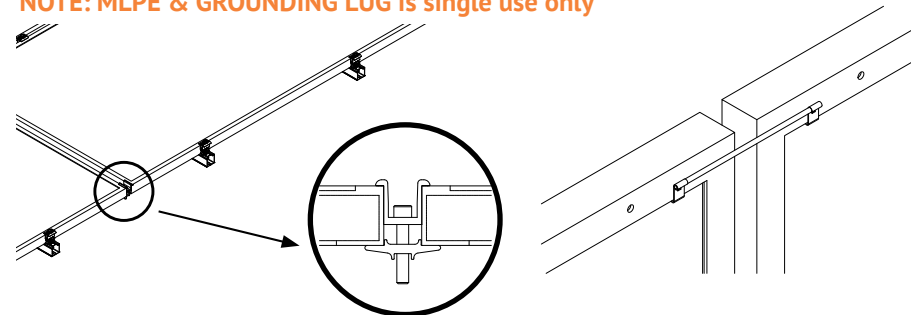

ALTERNATE ROW GROUNDING WITH N/S BONDING CLAMP:
 Insert clamp between module rows and tighten bolt.

TORQUE VALUE: 20 ft-lbs.

ALTERNATE ROW GROUNDING WITH N/S BONDING CLIP:
 Fully seat bonding clip on each module flange to provide bond across N/S module gap.

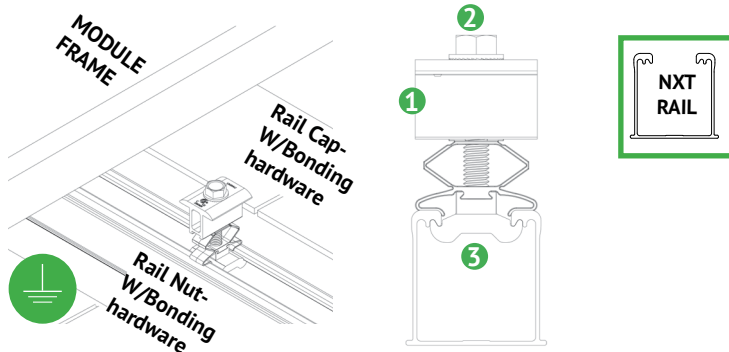

BONDING COMBO MID-END CLAMP ASSEMBLY

- 1 Aluminum combo mid-end clamp cap with stainless steel bonding pins that pierce module frame anodization to bond module to module through clamp
- 2 Stainless steel bolt bonds aluminum clamp to stainless steel Hex bolt
- 3 Aluminum combo mid-end clamp rail nut with stainless steel bonding pins that pierce rail anodization to bond module to module through clamp

NOTE: See Page 23 for installation details.

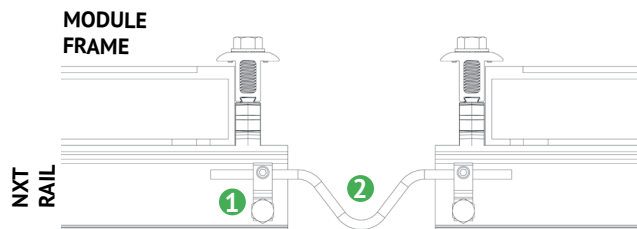

BONDING BETWEEN THERMAL BREAKS

- 1 Lug is connected at the end of each thermal break to the rail.
- 2 Solid copper wire is connected across the gap to bond the two ends.

NOTE: See Page 7 for installation details.

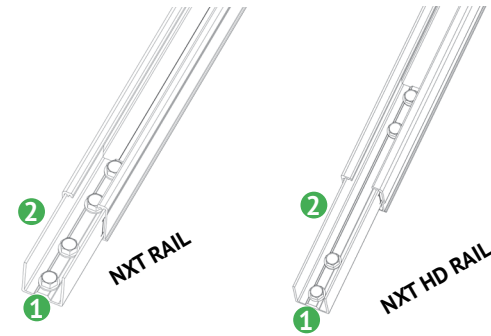

BONDING RAIL SPLICE

- 1 Bonding Hardware creates bond between Splice bar and each rail section.
- 2 Aluminum splice bar spans across rail gap to create rail to rail bond. Rail on at least one side of splice will be grounded.

NOTE:

- See Page 18 for installation details
- Splice certified for single-use only

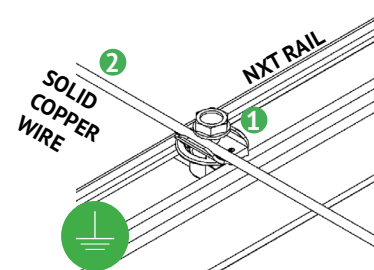

RACK SYSTEM GROUNDING

- 1 Tabs on the grounding plate pierce anodization on the rail to bond rail to ground wire.
- 2 Solid copper wire connected to lug is routed to provide final system ground connection.

NOTE: See Page 30 for installation details and alternate racking system grounding methods.

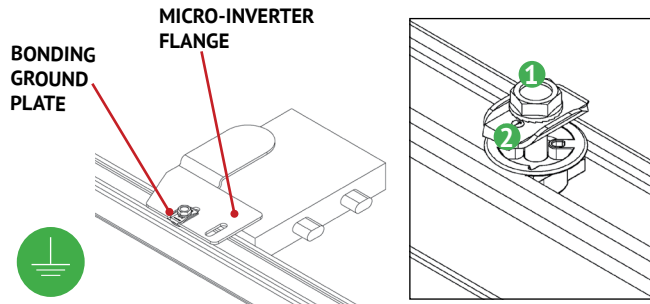

BONDING MICROINVERTER MOUNT

- 1 Serrations on the bolt head remove the anodization of MLPE flange and bonds.
- 2 Tabs on the stainless steel ground plate remove anodization on the rail and bonds.

NOTE: See Page 21 for installation details

CAUTION

- If loose components or loose fasteners are found during periodic inspection, re-tighten immediately.
- Any components showing signs of corrosion or damage that compromise safety shall be replaced immediately.

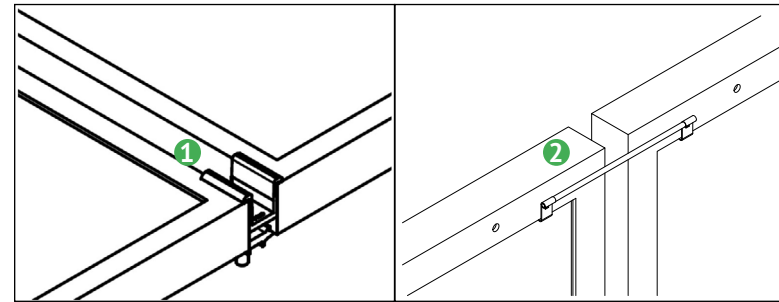

ALTERNATE ROW-TO-ROW BONDING PATHS

- 1 Row-to-row module bonding is accomplished with bonding clamp with 2 integral bonding pins.
- 2 Alternate method by connecting clips on either module to complete the bonding path.

NOTE:

- See Page 30 for installation details
- Row-to-row module bonding certified for single-use only



RACKING SYSTEM GROUND

Note: Only one lug per module row required

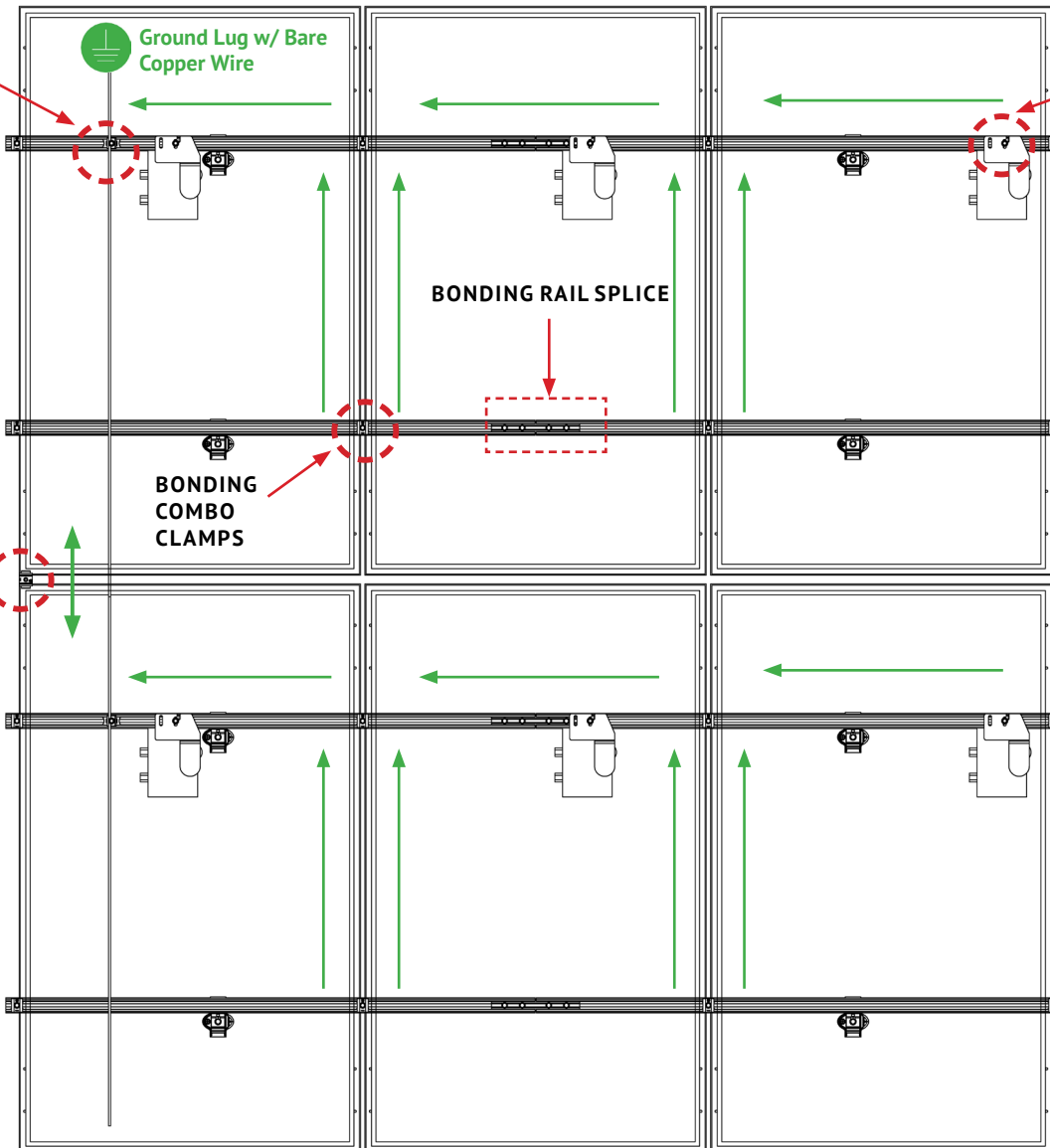

BONDING MICROINVERTER MOUNTS

BONDING RAIL SPLICE

BONDING COMBO CLAMPS

ALTERNATE ROW-TO-ROW BONDING METHOD

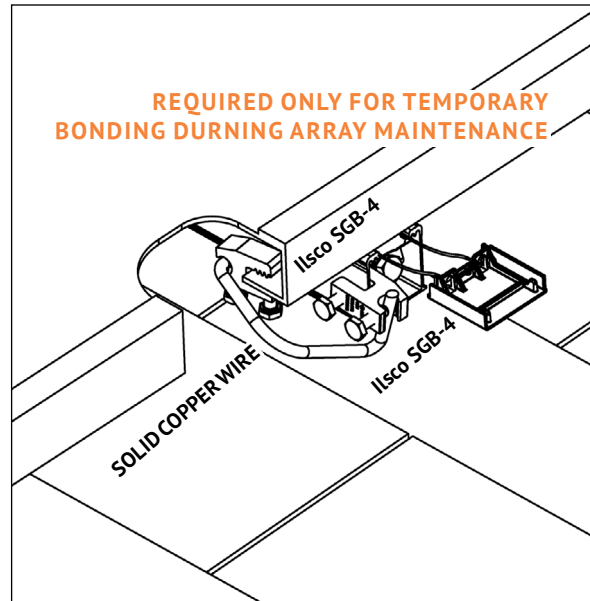
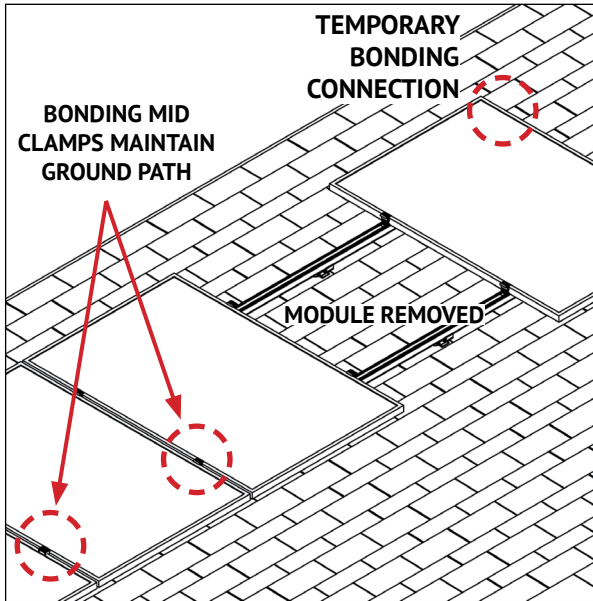

TEMPORARY BONDING CONNECTION DURING ARRAY MAINTENANCE

When removing modules for replacement or system maintenance, any module left in place that is secured with a bonding Midclamp will be properly grounded. If a module adjacent to the end module of a row is removed or if any other maintenance condition leaves a module without a bonding mid clamp, a temporary bonding connection must be installed as shown

- Attach IlSCO SGB4 to wall of rail
- Attach IlSCO SGB4 to module frame
- Install solid copper wire jumper to IlSCO lugs



Module removal may disrupt the bonding path and could introduce the risk of electric shock. Follow above mentioned instructions to maintain the bonding path.

ELECTRICAL CONSIDERATIONS

NXT UMOUNT is intended to be used with PV modules that have a system voltage less than or equal to that allowable by NEC. For standard system grounding a minimum 10AWG, 105°C copper grounding conductor should be used to ground a system, according to the National Electric Code (NEC). It is the installer's responsibility to check local codes, which may vary. See below for interconnection information.

INTERCONNECTION INFORMATION

There is no size limit on how many NXT UMOUNT & PV modules can be mechanically interconnected for any given configuration, provided that the installation meets the requirements of applicable building and fire codes.

GROUNDING NOTES

The installation must be conducted by a licensed and bonded electrician or solar contractor in accordance with the National Electric Code (NEC) and the authority having jurisdiction. Please refer to these resources in your location for required grounding lug quantities specific to your project.

The grounding / bonding components may overhang parts of the array so care must be made when walking around the array to avoid damage.

Conductor fastener torque values depend on conductor size. See product data sheets for correct torque values.

PERIODIC INSPECTION

Conduct periodic inspections for loose components, loose fasteners or any corrosion, immediately replace any affected components.

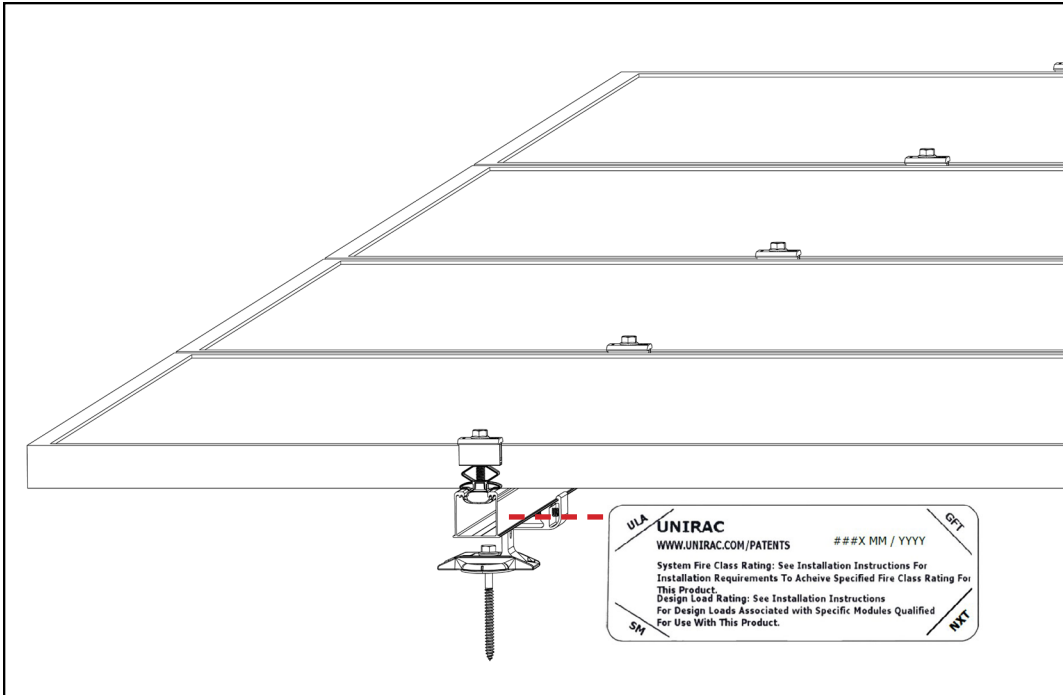

INSTALL UL2703 CERTIFICATION MARKING LABEL:

After the racking system is fully assembled, a single label should be applied to the rail at the edge of the array. One certification label is supplied in every box of 20 clamps.

Note:

- The sticker label should be placed such that it is visible.
- Cutoff all corners except NXT before applying on rail.

The NXT UMOUNT system has been certified and listed to the UL 2703 standard (Rack Mounting Systems and Clamping Devices for Flat-Plate Photovoltaic Modules and Panels). This standard included electrical grounding, electrical bonding, mechanical load and fire resistance testing.

SYSTEM LEVEL FIRE CLASSIFICATION

The system fire class rating requires installation in the manner specified in the NXT UMOUNT Installation Manual. NXT UMOUNT has been classified to the system level fire portion of UL 2703. NXT UMOUNT has achieved system level performance for steep sloped roofs and low sloped roofs. System level fire performance is inherent in the NXT UMOUNT design, and no additional mitigation measures are required. See table below for definition of steep sloped and low sloped roofs. The system is to be mounted over fire resistant roof covering rated for the application. There is no required minimum or maximum height limitation above the roof deck to maintain the system fire rating for NXT UMOUNT. Approved Module Types & System Level Fire Ratings are listed below:

Roof Type	Module Type	System Level Fire Rating	Rail Direction	Module Orientation
Steep Slope - roof pitches \geq 2 in/ft	Type 1, 2, 3 with metal frame, 10 with metal frame, 19, 22, 25, 29, 30 & 38	Class A	Parallel OR Perpendicular to Ridge	Landscape OR Portrait
Low Slope - roof pitches < 2in/ft	Type 1, 2, 29, 30 & 38			

MECHANICAL LOAD TEST MODULES

The modules selected for UL 2703 mechanical load testing were selected to represent the broadest range possible for modules on the market. The tests performed covers module frame thicknesses greater than or equal to 1.0 mm, single and double wall frame profiles (some complex frame profiles could require further analysis to determine applicability), and clear and dark anodized aluminum frames. PV modules may have a reduced load rating, independent of the NXT UMOUNT rating. Please consult the PV module manufacturer's installation manual for more information.

RAIL TYPE	Tested Module	Design Load Ratings	Tested Loads	Tested Module Area
NXT RAIL	SunPower SPR-A440 -COM	Down: 50 psf, Up: 50 psf , Slope: 15 psf	Down: 75 psf, Up: 75 psf , Slope: 23 psf	21.86 sq ft
	Jinko JKM-xxxM 72HL4-V	Down: 39.47 psf, Up: 22.28 psf, Slope: 8 psf	Down: 59.20 psf, Up: 33.42 psf, Slope: 12 psf	27.76 sq ft
	Q Cells Q Peak Duo XL-G11.3/BFG	Down: 37.06 psf, Up: 20.97 psf, Slope: 7.53 psf	Down: 55.60 psf, Up: 31.46 psf, Slope: 11.3 psf	29.49 sq ft
	QPEAK.DUO XL-G11S.3/BFG580	Down: 36.50 psf, Up: 20.96 psf, Slope: 7.6 psf	Down: 54.80 psf, Up: 31.45 psf, Slope: 11.4 psf	30.05 sq ft
NXT HD RAIL	JA Solar: JAM72D30-xxx/MB	Down: 50.47 psf, Up: 25.57 psf, Slope: 8.20 psf	Down: 75.7 psf, Up: 38.35 psf, Slope: 12.3 psf	27.81 sq ft

UL2703 CERTIFICATION MARKING:

Unirac NXT UMOUNT is listed to UL 2703. Certification marking is embossed on all Combo Clamps as shown. Labels with additional certification information are provided with clamps and must be applied to the NXT UMOUNT Rail at the edge of the array.

Note: This racking system may be used to ground and/or mount a PV module complying with UL1703/UL61730 only when the specific module has been evaluated for grounding and/or mounting in compliance with the included instructions.

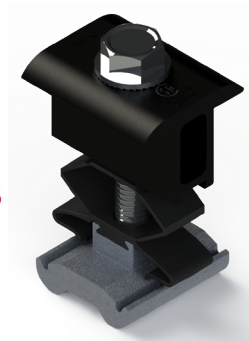

Electrical Bonding and Grounding Test Modules

The list below is not exhaustive of compliant modules but shows those that have been evaluated and found to be electrically compatible with the NXT UMount system.

Manufacture	Module Model / Series
Aionrise	AION60G1, AION72G1
Aleo	P-Series & S-Series
Aptos Solar	DNA-120-(MF/BF)10-xxxW DNA-120-MF10 DNA-120-(MF/BF)23 DNA-144-(MF/BF)23 DNA-120-(MF/BF)26 DNA-144-(MF/BF)26 DNA-108-(MF/BF)10-xxxW
Astronergy	CHSM6612 M, M/HV CHSM6612P Series CHSM6612P/HV Series CHSM72M-HC CHSM72M(DG)/F-BH
Auxin	AXN6M610T AXN6M612T AXN6P610T AXN6P612T AXNG1M SERIES
Axitec	AC-xxx(M/P)/60S, AC-xxx(M/P)/72S AC-xxxP/156-60S AC-xxxMH/120(S/V/SB/VB) AC-xxxMH/144(S/V/SB/VB)
Bluesun Solar	BSMxxxM10-72HBD
Boviet Solar	BVM6610, BVM6612 BVM6612M-XXXS-H-HC-BF-DG BVM7612M-H-HC-BF-DG
BYD	P6K & MHK-36 Series

Manufacture	Module Model / Series
Canadian Solar	CS1(H/K/U/Y)-MS CS3K-(MB/MB-AG/MS/P/P HE/PB-AG) CS3L-(MS/P), CS3N-MS CS3U-(MB/MB-AG/MS/P/P HE/PB/PB-AG) CS3W-(MB-AG/MS/P/P-PB-AG) CS3Y-MB-AG, CS5A-M CS6.1-54TM-H CS6.1-60TM-H CS6.1-72TB-H CS6.2-66TB-xxxH CS6K-(M/MS/MS AllBlack/P/P HE) CS6P-(M/P), CS6R-MS CS6R-xxxMS-HL CS6U-(M/P/P HE), CS6W-(MB-AG/MS) CS6W-xxx-TB-AG CS6X-P, CSX-P, CS7L-MB-AG CS7L-xxxMB-AG ELPS CS6(A/P)-MM
Centrosolar America	C-Series & E-Series
CertainTeed	CT2xxMxx-01, CT2xxPxx-01, CTxxxMxx-01 CTxxxPxx-01, CTxxxMxx-02, CTxxxMxx-03 CTxxxMxx-04, CTxxxHC11-04 CTM10400HC11-08, CTM10400HC11-09 CTM10400HC11-06, CTxxxHC11-06 CTTCxxxHC12-08
Eco Solargy	Orion 1000 & Apollo 1000
EMMVEE	ExxxHCBG144-T Titanium Clear

Manufacture	Module Model / Series
ET Solar	ET AC Module, ET Module ET-M772BH520-550WW/WB ET-M772BHxxxTW/TB
First Solar	FS-6XXX(A) FS-6XXX(A)-P, FS-6XXX(A)-P-I
Flextronics	FXS-xxxBB
Freedom Forever	FF-MP-BBB-xxx, FF-MP1-BBB-xxx
FreeVolt	PVGraf
GCL	GCL-P6 & GCL-M6 Series
Hansol	TD-AN3, TD-AN4 UB-AN1, UD-AN1
Hanwha SolarOne	HSL 60
Heliene	36M, 36P 60M, 60P, 72M & 72P Series 144HC M6 144HC M10 SL Bifacial 156HC M10 SL Bifacial
H-SAAE	HT60-156M-C HT60-156M(V)-C HT72-156(M/P) HT72-156P-C, HT72-156P(V)-C HT72-156M(PDV)-BF, HT72-156M(PD)-BF HT72-166M, HT72-18X
Hyperion Solar (Runergy)	HY-DH108P8(B), HY-DH108N8B HY-DH144P8 HY-DH156N8 HY-DH156P8

- The frame profile must not have any feature that might interfere with the bonding devices that are integrated into the racking system
- Use with a maximum over current protection device OCPD of 30A
- Unless otherwise noted, all modules listed above include all wattages and specific models within that series. Variable wattages are represented as "xxx"
- Items in parenthesis are those that may or may not be present in a compatible module's model ID
- Slashes "/" between one or more items indicates that either of those items may be the one that is present in a module's model ID
- **Listed models can be used to achieve a Class A fire system rating, for steep slope or low slope applications, only when modules of fire typed mentioned in Appendix A, Page 36 are used.**

Electrical Bonding and Grounding Test Modules

The list below is not exhaustive of compliant modules but shows those that have been evaluated and found to be electrically compatible with the NXT UMount system.

Manufacture	Module Model / Series	Manufacture	Module Model / Series	Manufacture	Module Model / Series
Hyundai	KG, MG, RW, TG, RI, RG, TI, KI, HI Series HiA-SxxxHG, HiD-SxxxRG(BK), HiN-SxxxXG(BK), HiS-S400PI, HiS-SxxxYH(BK), HiS-SxxxXG(BK) HiN-TxxxOJ HiN-TxxxNJ HiS-TxxxNJ HiN-TxxxNF(BK)	JA Solar (Cont.)	JAP72S##-xxx/** JAP6(k)-60-xxx/4BB, JAP60S##-xxx/** JAM6(k)-72-xxx/**, JAM72S##-xxx/** JAM6(k)-60-xxx/**, JAM60S##-xxx/** i. #: 01, 02, 03, 09, 10 ii. **: SC, PR, BP, HiT, IB, MW, MR ** = Backsheet, ## Cell technology	LG Electronics	LGxxx(E1C/E1K/N1C/N1K/N2T/N2W/S1C/ S2W/Q1C/Q1K)-A5 LGxxx(A1C/M1C/M1K/N1C/N1K/Q1C/Q1K/ QAC/QAK)-A6, LGxxxN2W-B3 LGxxxN2T-B5, LGxxxN1K-B6 LGxxx(N1C/N1K/N2T/N2W)-E6 LGxxx(N1C/N1K/N2W/S1C/S2W)-G4 LGxxxN2T-J5 LGxxx(N1K/N1W/N2T/N2W)-L5 LGxxx(M1C/N1C/Q1C/Q1K)-N5 LGxxx(N1C/N1K/N2W/Q1C/Q1K)-V5 LGxxxN3K-V6
Illuminate USA	IL5-72HBD-xxx M IL8-66HGD-xxx M	Jinko	JKM & JKMS Series JKMxxxM-6RL3-B JKMxxxM-72HBL-V JKMxxxM-72HL4-(T)V JKMxxxM-72HL4-TV JKMxxxM-72HLM-TV JKMxxxM-72HL-V JKMxxxM-7RL3-TV JKMxxxM-7RL3-V JKMxxxN-54HL4-B JKMxxxN-72HL4-BDV JKMxxxN-72HL4-BDX JKMxxxN-72HL4-TV	LONGi	LR4-60(HPB/HPH) LR4-72(HPH) LR5-54HABB-xxx M LR5-54-HPB-xxx M LR5-72HBD xxx M LR6-60 LR6-60(BK/HPB/HPH/HV/PB/PE/PH) LR6-72 LR6-72(BK/HV/PB/PE/PH) LR7-72HGD-xxx M LR8-66HGD-xxx M RealBlack LR4-60HPB RealBlack LR6-60HPB
Imperial Star	ISM7-SHDD108-400/M	Kyocera	KD-F & KU Series	Maxeon	SPR-MAX3-xxx-COM SPR-MAX3-XXX-R SPR-MAX3-XXX-BLK-R
Inception	mSolar 108BB HC Series (TXI10-xxx108BB) mSolar 144BB HC Series (TXS6-xxx144BB)	LA Solar	LSxxxHC(166), LSxxxBF, LSxxxBL, LSxxxHC, BLA Model		
ITEK	iT-SE Series				
Japan Solar	JPS-60 & JPS-72 Series				
JA Solar	JAM54D41-xxx/MB JAM54S30 xxx/MR JAM54S31 xxx/MR JAM6(K)-60/xxx JAM66D45 LB JAM72D30MB JAM72D40 xxx/MB JAM72S30 /MR JAM78D10MB JAP6(k)-72-xxx/4BB JAP6 60-xxx				

- The frame profile must not have any feature that might interfere with the bonding devices that are integrated into the racking system
- Use with a maximum over current protection device OCPD of 30A
- Unless otherwise noted, all modules listed above include all wattages and specific models within that series. Variable wattages are represented as "xxx"
- Items in parenthesis are those that may or may not be present in a compatible module's model ID
- Slashes "/" between one or more items indicates that either of those items may be the one that is present in a module's model ID
- **Listed models can be used to achieve a Class A fire system rating, for steep slope or low slope applications, only when modules of fire typed mentioned in Appendix A, Page 36 are used.**

Electrical Bonding and Grounding Test Modules

The list below is not exhaustive of compliant modules but shows those that have been evaluated and found to be electrically compatible with the NXT UMOUNT system.

Manufacture	Module Model / Series	Manufacture	Module Model / Series	Manufacture	Module Model / Series
Meyer Burger	Meyer Burger Black, Meyer Burger White Meyer Burger Glass				
Mission Solar Energy	MSExxxSX9R MSE Mono, MSE Perc MSExxx(SR8T/SR8K/SR9S/SX5T) MSExxx(SX5K/SX6W) MSExxxSX6Z MSExxxHT0B MSN10xxxHT4T	Phono Solar	PSxxxM1-20/U, PSxxxM1H-20/U PSxxxM1-20UH PSxxxM1H-20UH PSxxxM4(H)-24/TH PSxxxM1-20/UH PSxxxM1H-20/UH PSxxxM-24/T PSxxxMH-24/T PSxxxM-24/TH PSxxxMH-24/TH	Q Cells (Cont.)	Q.PEAK DUO L-G6.3 / BFG Q.PEAK DUO L-G8.3 (BFF/BFG/BGT) Q.PEAK DUO XL-(G10/G10.2/G10.3/G10.c/ G10.d) Q.PEAK DUO XL-(G11.2/G11.3) Q.PEAK DUO XL-(G9/G9.2/G9.3) Q.PEAK DUO XL-G10.3/BFG Q.PEAK DUO XL-G10.d/BFG Q.PEAK DUO XL-G11.3/BFG Q.PEAK DUO XL-G11S Q.PEAK DUO XL-G11S.3 / BFG Q.PEAK DUO XL-G9.3/BFG Q.TRON BLK M-G2+ AC Q.TRON BLK M-G2.H+ Q.TRON BLK M-G2.H1+/AC Q.TRON BLK M-G2+ SERIES Q.TRON M-G2+ SERIES Q.TRON XL-G2.3/BFG
Mitrex	Mxxx-L3H, Mxxx-I3H	Prism Solar	P72 Series, P72X-xxx	REC	RECxxxAA (BLK/Pure/Pure-R/ Pure-RX/ Pure 2/ Pro M) RECxxxNP (N-PEAK) RECxxxNP2 (Black) RECxxxNP3 Black RECxxxPE, RECxxxPE72 RECxxxTP, RECxxxTP72 RECxxxTP2(M/BLK2) RECxxxTP2S(M)72 RECxxxTP3M (Black) RECxxxTP4 (Black)
Mitsubishi	MJE & MLE Series				
mSolar	TXI10-xxx108BB				
Neo Solar Power Co.	D6M Series				
NE Solar	NESE xxx-60MH-M6 NESE xxx-72MHB-M10 NESE xxx 72MHT-M10 NESE xxx 72THB-M10 NESE xxx 72MHB-M10	Q Cells	Peak G5(SC) , G6(+)(SC)(AC), G7, G8(+), Peak L-G5, L-G6, L-G7, L-G8(BFF) Plus, Pro, Peak, G3, G4, Plus, Pro, Peak L-G2, L-G4, L-G5 Q.PEAK DUO(BLK)-G6+ Q.PEAK DUO (BLK)-G7 Q.PEAK DUO (BLK) G8(+) Q.PEAK DUO (BLK) ML-G10(a)(+) Q.PEAK DUO (BLK) ML-G9(+) Q.PEAK DUO BLK G10(+) Q.PEAK DUO BLK G10+ /AC Q.PEAK DUO BLK-G6+/TS Q.PEAK DUO BLK ML-G10.B+ Q.PEAK DUO BLK ML-G10+ / t Q.PEAK DUO BLK ML-G10+ / TS Q.PEAK DUO BLK ML-G10.C+ Q.PEAK DUO-G10+ Q.PEAK DUO L-(G7/G7.1/G7.2/G7.3/G7.7) Q.PEAK DUO L-(G8/G8.1/G8.2/G8.3)		
Panasonic	VBHNxxxSA06/SA06B/SA11/SA11B VBHNxxxSA15/SA15B/SA16/SA16B, VBHNxxxKA, VBHNxxxKA03/04, VBHNxxxSA17/SA17G/SA17E/SA18/SA18E, VBHNxxxZA01/ZA02/ZA03/VBHNxxxZA04 EVPVxxx EVPVxxx(H/K/PK/HK/HK2)				
Peimar	SGxxxM (FB/BF) SMxxxM				
Philadelphia Solar	PS-M108(HCBF)-400W (30 & 35mm frames)				

- The frame profile must not have any feature that might interfere with the bonding devices that are integrated into the racking system
- Use with a maximum over current protection device OCPD of 30A
- Unless otherwise noted, all modules listed above include all wattages and specific models within that series. Variable wattages are represented as "xxx"
- Items in parenthesis are those that may or may not be present in a compatible module's model ID
- Slashes "/" between one or more items indicates that either of those items may be the one that is present in a module's model ID
- **Listed models can be used to achieve a Class A fire system rating, for steep slope or low slope applications, only when modules of fire typed mentioned in Appendix A, Page 36 are used.**

Electrical Bonding and Grounding Test Modules

The list below is not exhaustive of compliant modules but shows those that have been evaluated and found to be electrically compatible with the NXT UMOUNT system.

Manufacture	Module Model / Series
Renesola	All 60-cell modules
Risen	RSM Series, RSM110-8-xxxBMDG
SEG Solar	SEG-xxx-BMD-HV, SEG-xxx-BMD-TB SEG-XXX-BMB-TB, SEG-xxx-BMA-HV SEG-xxx-BMA-TB, SEG-xxx-BMB-HV SEG-xxx-BMA-BG, SEG-xxx-BMB-BG SEG-xxx-BTA-BG, SEG-xxx-BTB-BG SEG-xxx-BMD-BG, SEG-xxx-BTD-BG
S-Energy	SN72 & SN60 Series SL45-60BG1/BHI SL45-60MBI-xxxZ
Seraphim	SEG-(6PA/6PB/6MA/6MA-HV/6MB/E01/E11) SRP-(6QA/6QB) SRP-xxx-6MB-HV, SRP-320-375-BMB-HV, SRP-xxx-BMC-HV, SRP-390-450-BMA-HV, SRP-xxx-BMZ-HV, SRP-390-405-BMD-HV
Sharp	NU-SA & NU-SC Series
Silfab	SLA-M, SLA-P, SLG-M, SLG-P & BC Series SILxxx(BG/BK/BL/HC+/HL/HM/HN/ML/ NL/NT/NX/NU/QD/QM) SIL-xxx XM, SIL-xxx XM+
Sirius	ELNSM54M-HC-BF Series ELNSM54M-HC Series
Solar4America	S4Axxx-108MH10BB, S4Axxx-72MH5BB S4Axxx-144MH10xxx, S4Axxx-144TH10xxx S4Axxx-144TH16xxx, S4Axxx-108MH10xxx S4Axxx-108TH10xxx

Manufacture	Module Model / Series
SolarEver USA	SE-166*83-xxxM-120N SE-182*91-xxxM-108N SE-182*105-xxxM-96-BD
Solaria	PowerXT-xxxR-(AC/PD/BD) PowerXT-xxxC-PD PowerXT-xxxR-PM (AC) PowerX-400R
Solartech	STU HJT, STU PERC & Quantum PERC
SolarWorld	Sunmodule Protect, Sunmodule Plus/Pro
Sonali	SS-M-360 to 390 Series SS-M-390 to 400 Series SS-M-440 to 460 Series SS-M-430 to 460 BiFacial Series
Sun Edison	F-Series, R-Series
Suniva	MV Series & Optimus Series (35mm)
Sunmac Solar	M754SH-BB Series
SunPower	AC, X-Series, E-Series & P-Series SPR E20 435 COM (G4 Frame) Axxx-BLK-G-AC, SPR-Mxxx-H-AC SPR-Mxxx-BLK-H-AC
SunTech	STP, STPXXXS - B60/Wnhb
Talesun	TP572, TP596, TP654, TP660 TP672, Hipor M, Smart TD6I72M, TP7G54M(H) TD7G72M TM7G54M

Manufacture	Module Model / Series
Tesla	SC, SC B, SC B1, SC B2, TxxxS, TxxxH
Thornova	TS-BG54 TS-BG72
Trina	DE06, DE09.05, DE09C.07 DEG15HC.20(II), DEG15MC.20(II) DEG15VC.20(II), DE18M(II), DEG18MC.20(II) DE19, DEG19C.20 PA05, PD05, DD05, DD06 PD14, PE14, DD14, DE14, DE15, DE15V(II) TSM-DE06X.05(II) TSM-DE09.05 TSM-DE09.08 TSM-DE09C.07 TSM-NE09RC.05 TSM-NE09RH.05 TSM-NE19RC TSM-NEG19RC.20
TSMC	TS-150C2 CIGSw
Universal Solar	UNI4xx-144BMH-DG UNI5xx-144BMH-DG UNIxxx-108M-BB UNIxxx-120M-BB UNIxxx-120MH
Upsolar	UP-MxxxP, UP-MxxxM(-B)

- The frame profile must not have any feature that might interfere with the bonding devices that are integrated into the racking system
- Use with a maximum over current protection device OCPD of 30A
- Unless otherwise noted, all modules listed above include all wattages and specific models within that series. Variable wattages are represented as "xxx"
- Items in parenthesis are those that may or may not be present in a compatible module's model ID
- Slashes "/" between one or more items indicates that either of those items may be the one that is present in a module's model ID
- **Listed models can be used to achieve a Class A fire system rating, for steep slope or low slope applications, only when modules of fire typed mentioned in Appendix A, Page 36 are used.**

Electrical Bonding and Grounding Test Modules

The list below is not exhaustive of compliant modules but shows those that have been evaluated and found to be electrically compatible with the NXT UMOUNT system.

Manufacture	Module Model / Series
URECO	D7Kxxx(H7A/H8A), D7Mxxx(H7A/H8A) F6MxxxE7G-BB FAKxxx(C8G/E8G), FAMxxxE7G-BB FAMxxxE8G(-BB), FBKxxxM8G FBMxxxM7G-BB FBMxxxMFG-BB
Vikram Solar	Eldora, Somera, Ultima PREXOS VSMDHT.60.AAA.05 PREXOS VSMDHT.72.AAA.05 Paradea VSMDH.72.AAA.05
Vina	VNS-72M1-5-xxxW-1.5, VNS-72M3-5-xxxW-1.5, VNS-144M1-5-xxxW-1.5, VNS-144M3-5-xxxW-1.5, VNS-120M3-5-xxxW-1.0
VSUN	VSUNxxx-60M-BB VSUNxxx-72MH VSUN4xx-144BMH VSUN4xx-144BMH-DG VSUN5xx-144BMH-DG VSUNxxx-108M-BB VSUNxxx-120M-BB VSUNxxx-120BMH VSUNxxx-132BMH VSUNxxx-108BMH VSUNxxxN-144BMH VSUNxxxN-144MH

Manufacture	Module Model / Series
VSUN (Cont.)	VSUNxxx-144BMH VSUNxxx-144MH VSUNxxx-144M-BW VSUNxxx-144M-BB
Waaree	Arka Series WSMDi
Winaico	WST & WSP Series
Yingli	YGE & YLM Series
Yotta Energy	YSM-B450-1
ZNShine Solar	ZXM6-72 Series ZXM6-NH120 Series ZXM6-NH144 ZXM6-NHLDD144 ZXM7-SH108 Series ZXM7-SHDB144 ZXM7-SHLDD144 ZXM7-UHLDD144

- The frame profile must not have any feature that might interfere with the bonding devices that are integrated into the racking system
- Use with a maximum over current protection device OCPD of 30A
- Unless otherwise noted, all modules listed above include all wattages and specific models within that series. Variable wattages are represented as "xxx"
- Items in parenthesis are those that may or may not be present in a compatible module's model ID
- Slashes "/" between one or more items indicates that either of those items may be the one that is present in a module's model ID
- **Listed models can be used to achieve a Class A fire system rating, for steep slope or low slope applications, only when modules of fire typed mentioned in Appendix A, Page 36 are used.**